

# ALMA/IRAM Activities

Status As Of 03-Jul-2001

Prepared for the JRDG teleconf of 05-Jul-2001

## Mixer development

### Baseline DSB mixer

(A.Navarrini)

A full height waveguide SIS mixer for ALMA band 7 has been realized. The fixed tuned single junction Nb/Al-AIO<sub>x</sub>/Nb mixer operates in DSB. The operating bandwidth is achieved by using a parallel tuning inductor with a radial microstrip stub to tune out the junction capacitance of 75 fF (junction size 1 μm<sup>2</sup>). The junction is coupled to an antenna which stretches only part way across the waveguide. An Inductively Loaded Microstrip Line (ILML) sometimes called Capacitively Loaded Coplanar Waveguide (CLCPW) is used for the double purpose of :

- matching the RF impedance of the junction to the low real value (~75 Ω) of the antenna impedance.
- fulfilling a derived stability criterion of the DSB mixer in the operating frequency band.

The first junction was recently tested and actually achieves a rather large bandwidth: 225–370GHz (45%). It remains to be seen whether such bandwidth can be reproduced in subsequent measurements.

Next figures show a photograph of the mixer chip and a 3D view of the mixer block.

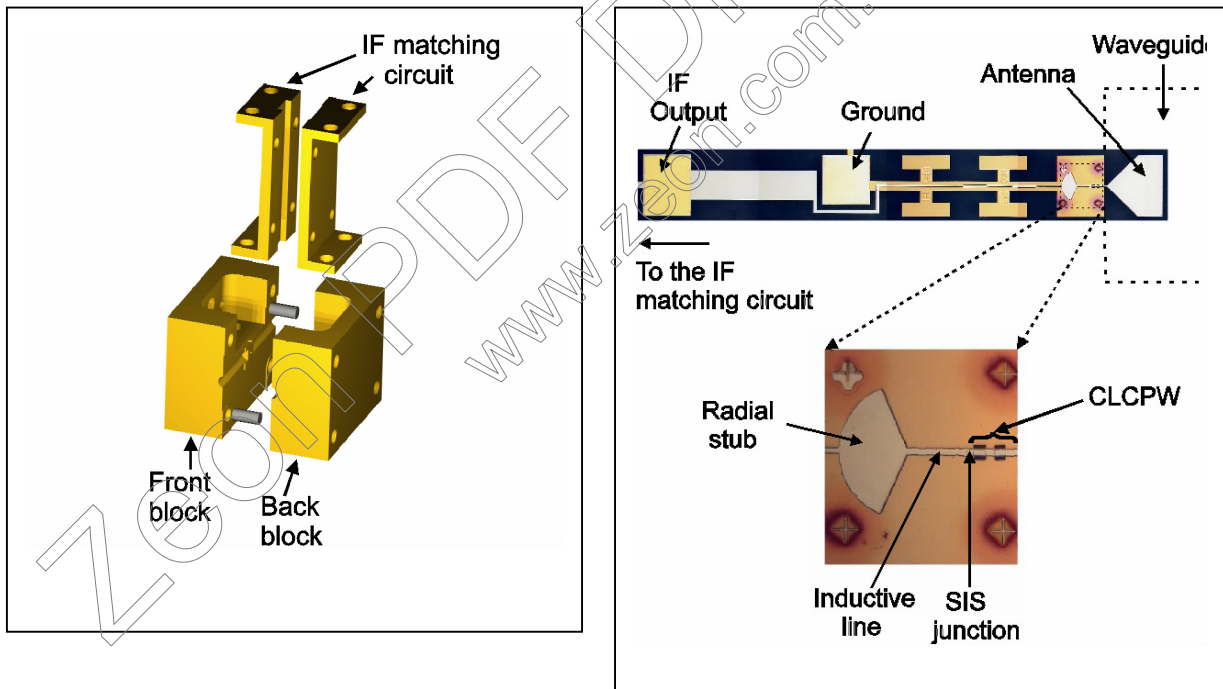

We have tested the receiver by using a quasi-optical injection for the LO with a wire grid. An IF amplifier with  $\nu_{IF}=4$  GHz ( $\Delta\nu_{IF}=1$  GHz),  $T_{IF}=5$  K is used. The DSB receiver noise temperature measured to the input of the grid is reported as a function of frequency in the following figure. We point-out that this result refers to the first ever junction mounted in the mixer block and that a systematic characterization of the mixer is in progress.

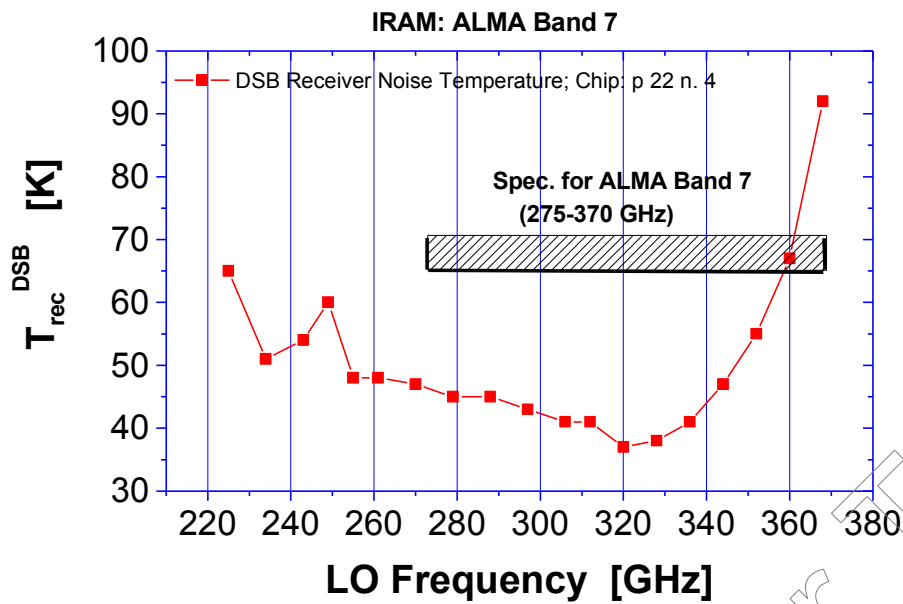

### Mixer development beyond baseline

(D.Maier)

Design work is in progress for a new version of the mixer chip with lower output capacitance, to increase the IF bandwidth. It is also planned to test configurations of balanced and 2SB mixers; see below section on coupler development.

### Waveguide quadrature hybrid coupler

(S.Claude)

We present the development of waveguide quadrature hybrid. Couplers for 230 GHz and 320 GHz

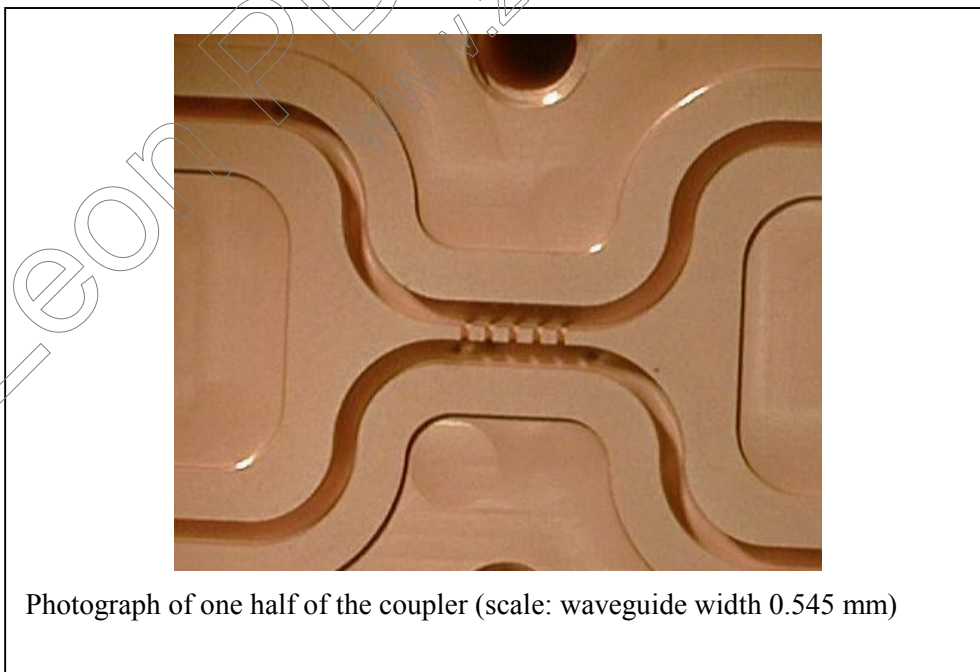

have been manufactured using spark erosion for the 5 slots (width of 0.189 mm and 0.133 mm respectively). Full tests have been done at 230 GHz, using the IRAM vector network analyzer.

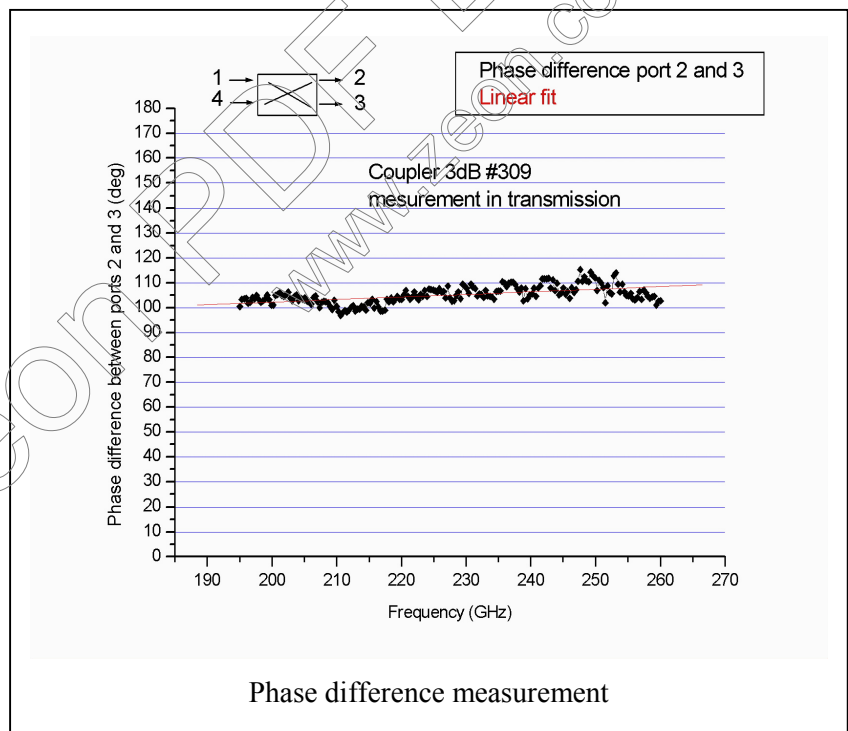
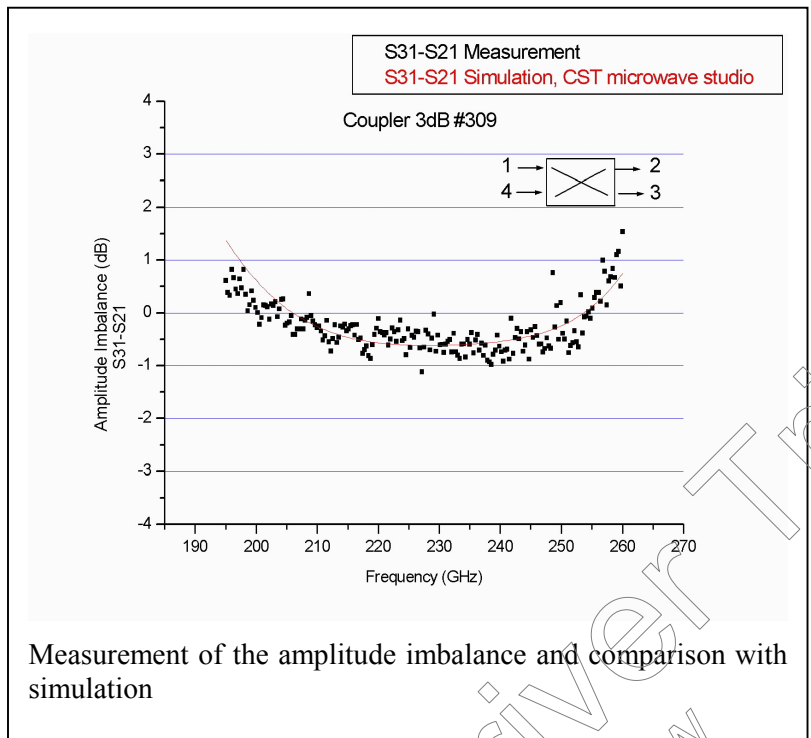

This type of coupler will now be used for developing LO couplers, balanced mixers and sideband separation mixers.

## Band 7 Cartridge

(S.Claude)

Two optics designs are currently being studied.

- a) The baseline design that was presented at the PDR has the advantage of allowing enough space for arranging the mixers, LO couplers and feedhorns in DSB or 2SB configuration. The focal distance of the input off-axis mirror is such that the beam squint is as low as for the compensating mirrors method (see note below).
- b) The design proposed for Band 8 has no cross-polarization because the polarization grid is placed at the input of the cartridge. This layout has the disadvantage of not providing a lot of space for the mixers and LO couplers. The 2SB option might not be feasible in that configuration.

Note: The cross polarization due to coupling of the fundamental mode to the  $E_{01}$  mode can be cancelled in a two refocusing mirrors configuration, as shown by Murphy (1997). However, this requires not only equal amplitudes of coupling of the two mirrors, but also a phase slippage of  $\pi$ . The latter condition requires both mirrors to be in the far field of the intermediate waist, and can be achieved only asymptotically. In practice, and taking into account space limitation, as in the present cartridge design, perfect cancellation cannot be achieved and other non-canceling configurations can achieve similar results.

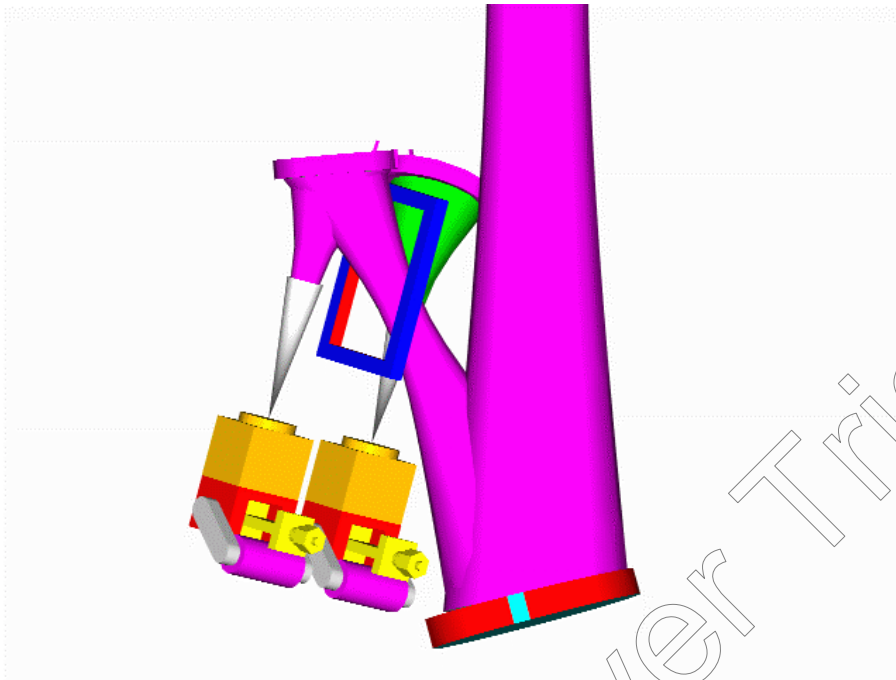

Design a) side view

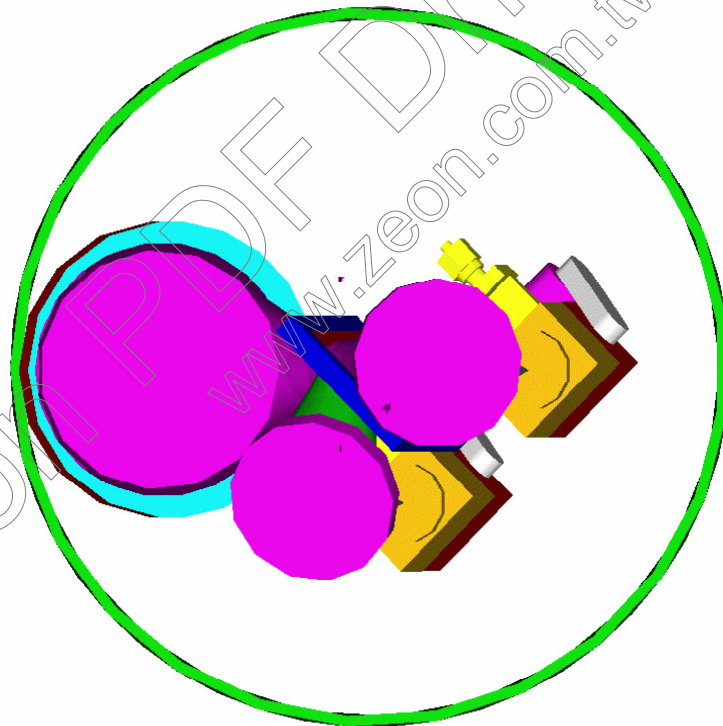

Design a) top view

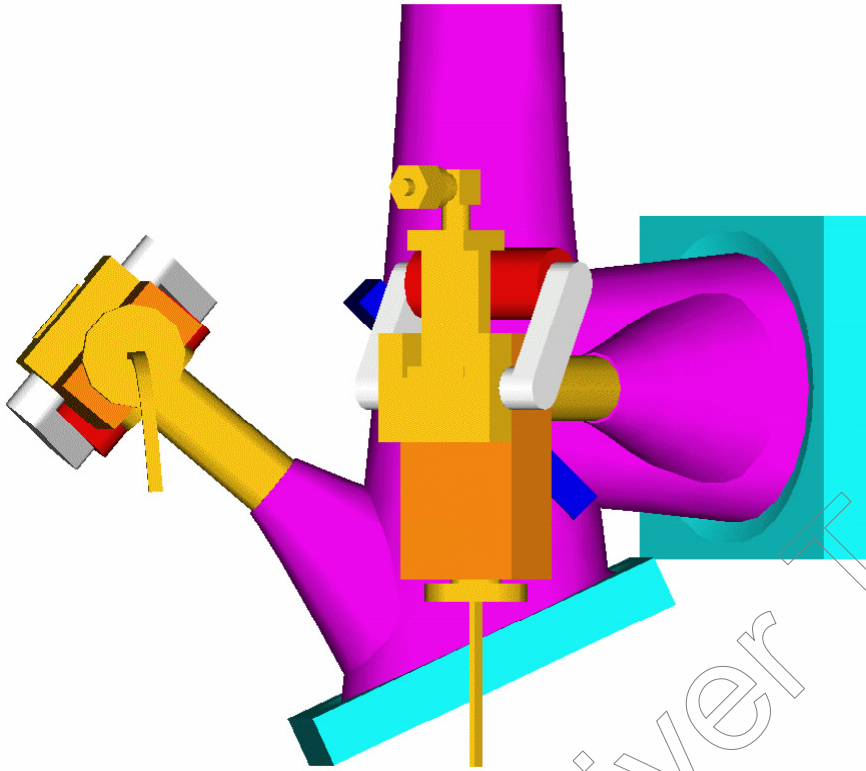

Design b) sideview

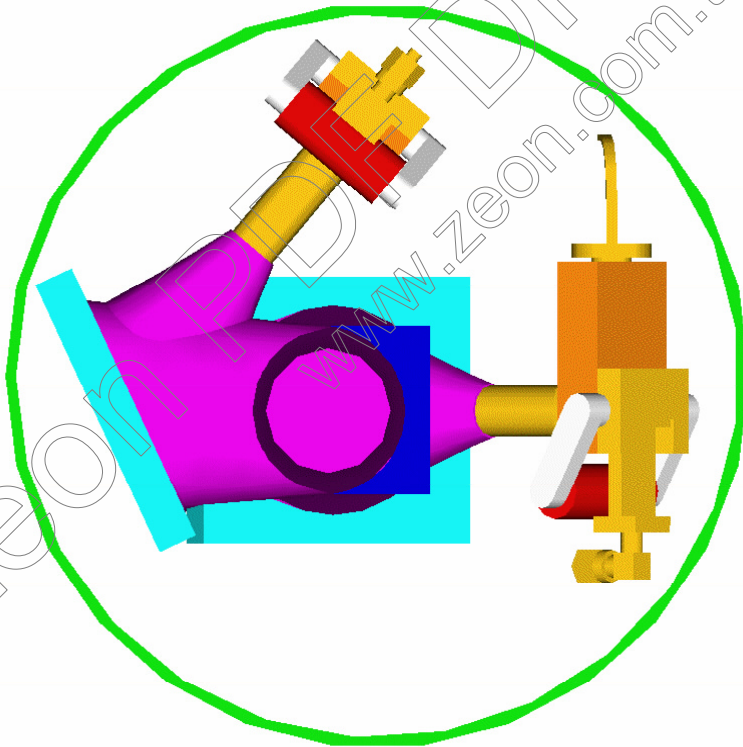

Design b) top view

## Calibration vanes & IR filters

(B.Lazareff)

Several samples have been collected and their absorption measured at three frequencies: 100, 225, and 320GHz. The samples are listed below:

Designation	Manufacturer	Thickness (mm)	Notes
Styrodur 3035S	BASF	41	green, rigid
Styrodur 2505	BASF	21	green,rigid
Eccostock SH2	Emerson Cuming	51	white, rigid, 2lb/cuft
Eccostock PP2	Emerson Cuming	3.17	white, flexible, 2lb/cuft
		6.35	
C-Stock RH-5	Acofab	3.17	white, rigid
		6.35	
C-Foam PF-2	Acofab	3.17	white, flexible
		6.35	

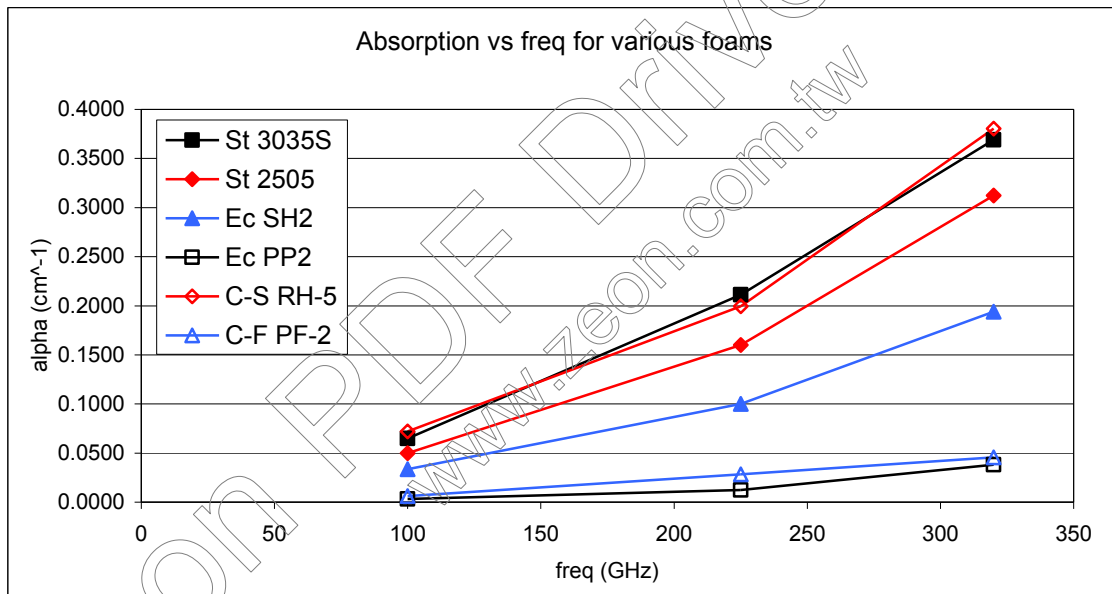

More details will be given in a forthcoming memo. The four materials with the higher absorption may be suitable for the vane calibration method, (Plambeck; Guilloteau and Moreno). The fact that the absorption coefficient rises roughly as  $\nu^{1.5}$  may allow to have a single vane for all frequencies between 85 and 300 GHz. Two materials have low losses and might be suitable for IR filters.