



Memorandum

To: K. Crady G. Ediss
R. Groves A. R. Kerr
D. Koller G. Lauria
M. Pospieszalski S. -K. Pan
S. Srikanth J. Webber

From: J. Effland

Date: 18 October 2000
2 July 2001 (Revised to add file name to footer)

Subject: Recent Data Characterizing the SIS Noise Temperature Measurement System

Summary

The primary intent of this memo is to show that the chopper wheel system can now measure receiver noise temperatures with nearly the same accuracy as the conical loads. The effective temperature assumed for the chopper's cold load is 94.5K from 200 to 260 GHz and 93K from 260-300 GHz. Figure 11 shows that there is now a $\pm 5\%$ discrepancy between the conical load and chopper-based receiver temperatures.

The untuned LO tripler was suspected of degrading the receiver noise temperature, but Figure 3 shows nearly identical receiver noise temperatures using two different untuned tripler designs.

Also presented are mixer/preamp characteristics for the UVAV-L811A-D5-2-D2-374C-01 single-ended mixer married to the IF4-12P.02 preamp measured over 50 frequencies across the 4-12 GHz IF band.

Finally, preliminary estimates are given of the ohmic losses for the reflector used with the chopper wheel. Figure 14 shows that the ohmic losses are about 0.2 dB, and that the chopper's effective cold load temperature would be about 85K if the reflector was lossless.

I wish to thank Ralph Groves for collecting most of the data shown in this report.

Background

Encouraging results^{1,2} have been previously obtained for receiver noise temperatures measured using the chopper wheel when compared to the lab's standard conical loads. The latest data presented in this memo includes significantly more measurement points obtained by measuring noise temperatures over 50 IF frequencies at each LO frequency. This high level of frequency resolution provides additional insight into the results. For example, a short period ripple in the noise temperature data was quickly traced to improper positioning of the ambient load

¹ "Noise Temperatures Measured Manually and with Chopper Wheel", J. Effland, NRAO CDL Internal Memo, 2000-07-28

² "Cold Load Measurements", J. Effland, K. Xiluri, R. Groves, NRAO CDL Internal Memo, 2000-01-10.

Measurement Setup

The measurement setup for testing mixer/preamp combinations is diagrammed in Figure 1. The 0.5 dB load in front of the first amplifier on the warm IF plate provides a return path to ground for the first stage gate of that amplifier. Ron Harris claims this dramatically reduces amplifier failures, because the Miteq amplifiers are designed with floating gates that provide no return path to ground. The measured noise temperature of the warm IF plate, referred to the input filter, is shown in Figure 2. This was measured using an HP 346B coaxial noise source.

The laboratory standard loads are fabricated from sheets of Eccosorb AN72 absorber formed to the shape of a cone. The absorber is 9 cm in diameter inside the base of the cone and the internal height of the cone is 15 cm. The outside of the cold load' cone is enclosed in a copper case and the entire assembly is dipped in a bath of liquid nitrogen to cool it. The ambient load is a section of AN72 absorber without the copper casing and the base of its cone and is 9 cm with a height of 17 cm.

The chopper wheel is 35.6 cm in diameter and reflects the beam from the Dewar window into either an ambient load, or through a 44-cm square aluminum reflector to a cold load. The cold load is Eccosorb CV-3 absorber enclosed in a Styrofoam cylinder of dimensions 8-cm high and 14 cm in diameter. Liquid nitrogen was added to the bowl to cover the absorber tips.

An HP 436 power meter is used to measure Y-factors for all measurements. The noise powers of the mixer/amp and the warm IF system differ by as much as 30 dB. The existing HP 8484A Power head samples data at a slow rate of about 1 measurement per second when the power is less than -50 dBm (10 nW), so a new E4412A power head has been ordered to significantly speed up data acquisition.

Figure 3 shows that spurious signals are probably not being generated by the triplers in the LO system. Marian Pospieszalski suggested that the noise temperature increase near the 5 GHz IF frequency could be caused by spurious signals generated by the untuned triplers. Figure 3 shows identical receiver noise temperatures at 210 GHz using two different tripler designs.

Load Material Tests

The optimum load material for the two available types was determined by comparing receiver noise temperatures measured with ambient loads made with AN-72 and CV-3 to the conical loads. The AN-72 is a flat sheet, and CV-3 is pyramidal. Both loads were cut from new material. Figure 4 graphs receiver noise temperatures measured at 230 GHz for these three types of loads. The cold load temperature for the chopper-based measurements was adjusted to 94.5K. The best agreement between the conical load data and chopper-based data is found when the hot load is made from CV-3. All the remaining noise temperature data was measured with CV-3 for both the ambient and cold loads.

Noise Temperature Comparisons

Receiver noise temperatures measured with the conical loads and chopper wheel are show in Figure 5 to Figure 10. Also plotted in each figure is the measured noise temperature of the warm IF system, referred to the receiver input.

Discrepancies between receiver noise temperatures measured with conical load data and with the chopper wheel are shown in Figure 11. The large discrepancy at 210 GHz most likely results from the noise temperature spike there, as shown in Figure 5. The spike is sharp, and its characteristics change rapidly with IF frequency and perhaps with time, so measurements near that frequency might exhibit large variations.

The effective temperature assumed for the chopper's cold load is 94.5K from 200 to 260 GHz and 93K from 260-300 GHz. Figure 11 shows that there is now a $\pm 5\%$ discrepancy between the conical load and chopper-based receiver temperatures, which is near the measurement uncertainty.

Mixer/Preamp Gain Measurements

Gain measurements for the combined mixer/preamp are shown in Figure 12, and were derived from noise power and physical temperature measurements as described below.

Using an extension of the Rayleigh-Jeans law, where G is the gain of the system, k is Boltzmann's constant, T is the physical temperature in Kelvin, and B is the bandwidth in Hz:

$$P_{NOISE} = GkTB$$

the gain³ is obtained from differencing noise power and physical temperature measurements. The overall system "gain" is measured from the RF input, where $P_{RF,HOT}$ and $P_{RF,COLD}$ are noise powers measured using the hot and cold loads with physical temperatures of $T_{RF,HOT}$ and $T_{RF,COLD}$ respectively:

$$G_{RF} = \frac{P_{RF,HOT} - P_{RF,COLD}}{T_{RF,HOT} - T_{RF,COLD}}$$

The system "gain" referred to the coax switch inside the Dewar is similarly:

$$G_{IF} = \frac{P_{IF,HOT} - P_{IF,COLD}}{T_{IF,HOT} - T_{IF,COLD}}$$

Since the gain of the IF system is included in G_{RF} above, the true mixer/preamp gain is obtained from ratioing the RF and IF gains:

$$G_{MIXER/PREAMP} = 10 \text{Log}_{10} \left(\frac{G_{RF}}{G_{IF}} \right)$$

Loss of Reflector Surface Used with Cold Load

To obtain insight into the high effective cold load temperature of the chopper-based cold load, Geoff Ediss recommended measuring noise temperatures with inserting two reflectors between the receiver and cold load. An increase in receiver noise temperature measured using these two reflectors results from scattering and losses incurred in the second reflector.

Receiver noise temperature data were measured several times with a single reflector, as show in Figure 13. Next, the cold load was configured to use a second reflector, and another set of noise temperatures was measured, also shown in Figure 13.

The loss of the second reflector was determined from the receiver noise temperature increase by assuming that the second reflector acts like an attenuator located between the receiver input and the cold load. Given a receiver with noise temperature T_{RX} and an attenuator in front of the receiver with loss L ($0 \leq L \leq \infty$) at a physical temperature of $T_{Physical, Loss}$, the noise temperature of the receiver (T'_{RX}) becomes:

³This is actually the gain normalized by Boltzmann's constant and the bandwidth, which are reduced when two such "gains" are ratioed.



$$T'_{RX} = LT_{RX} + (L - 1)(T_{Physical, Loss})$$

Rearranging the above provides the loss:

$$L = \frac{T'_{RX} + T_{Physical, Loss}}{T_{RX} + T_{Physical, Loss}}$$

The calculated ohmic losses of the second reflector are shown in Figure 14. Although the calculations assume that the entire noise increase from the second reflector results from ohmic losses, the 6061-T6 aluminum reflector had a rough surface finish, and scattering losses may be significant. Additional tests are planned with a second reflector polished to a near optical finish to more closely match the finish of the single reflector that is used in the measurement system. The reason for the apparent loss increase over such a small fractional bandwidth is unknown. Also shown in the figure is the calculated effective temperature of the chopper's cold load if a lossless reflector were used.

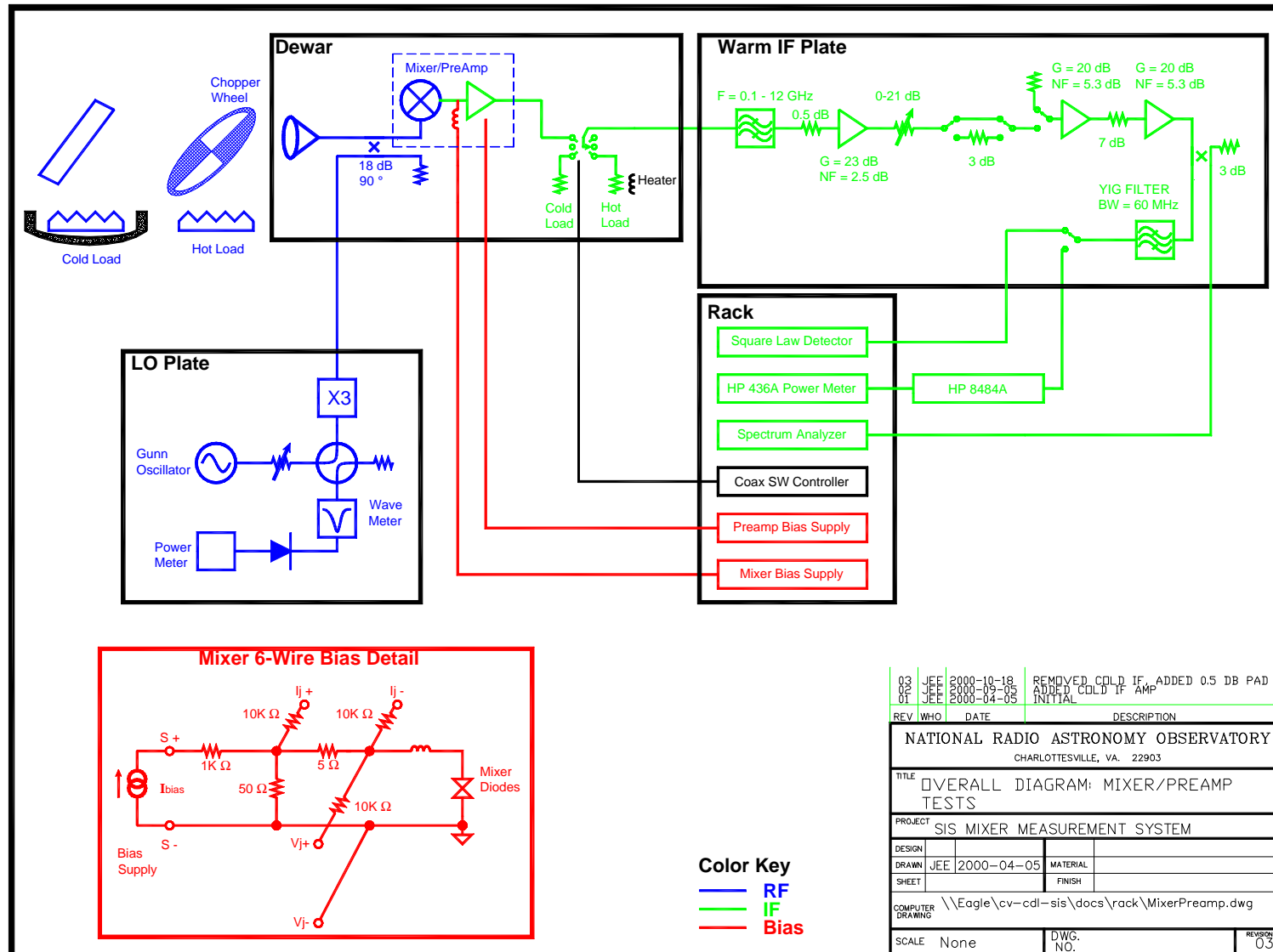

Figure 1: Measurement Setup



Warm IF Plate Noise Figure

First Amp: AFS3-00101200-42-LN, SN 359287

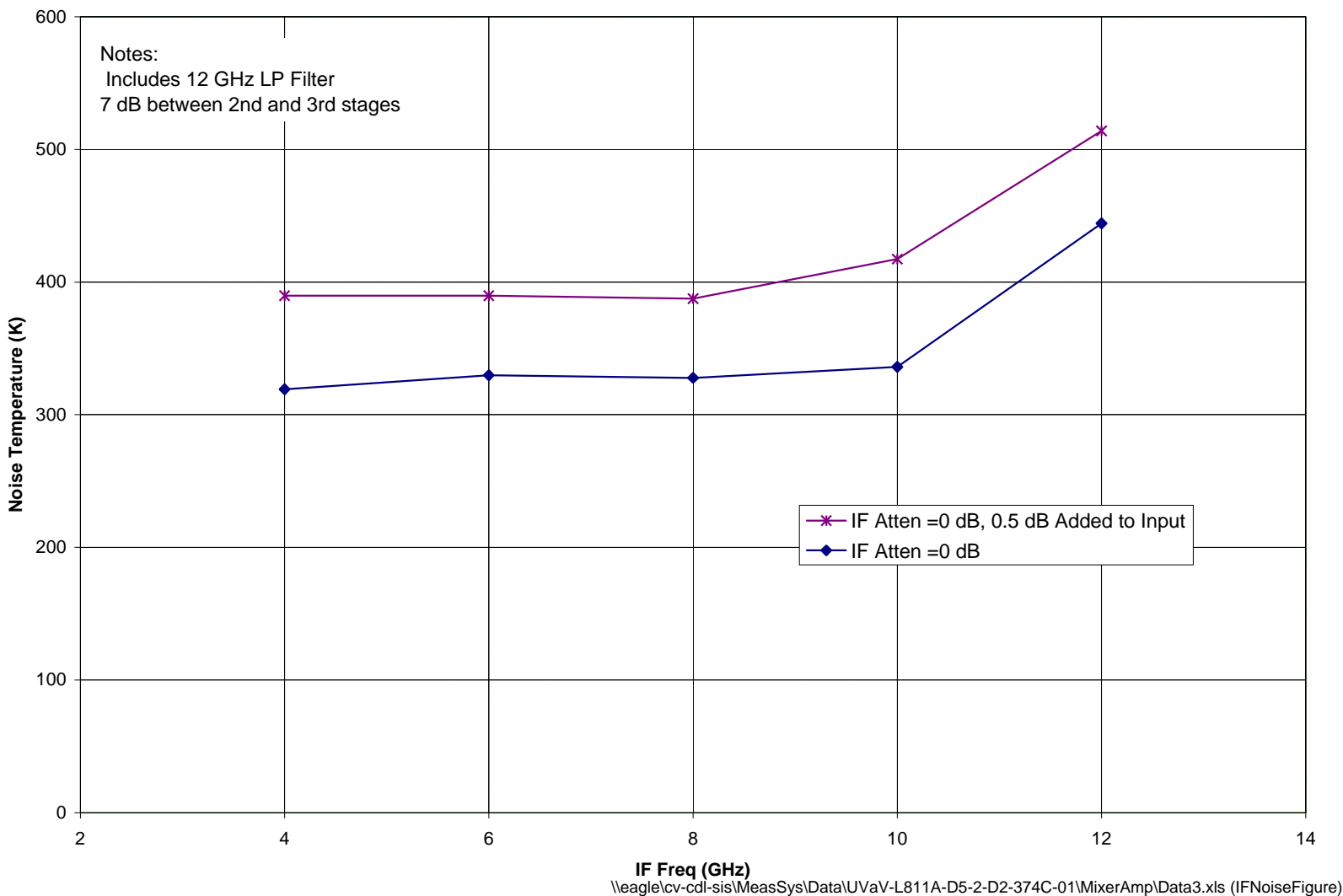

Figure 2: Measured Noise Temperature of Warm IF Plate

Noise Temperature Data 210 GHz
UVAV-L811A-D5-2-D2-374C-01+IF4-12P.02
2000-09-27

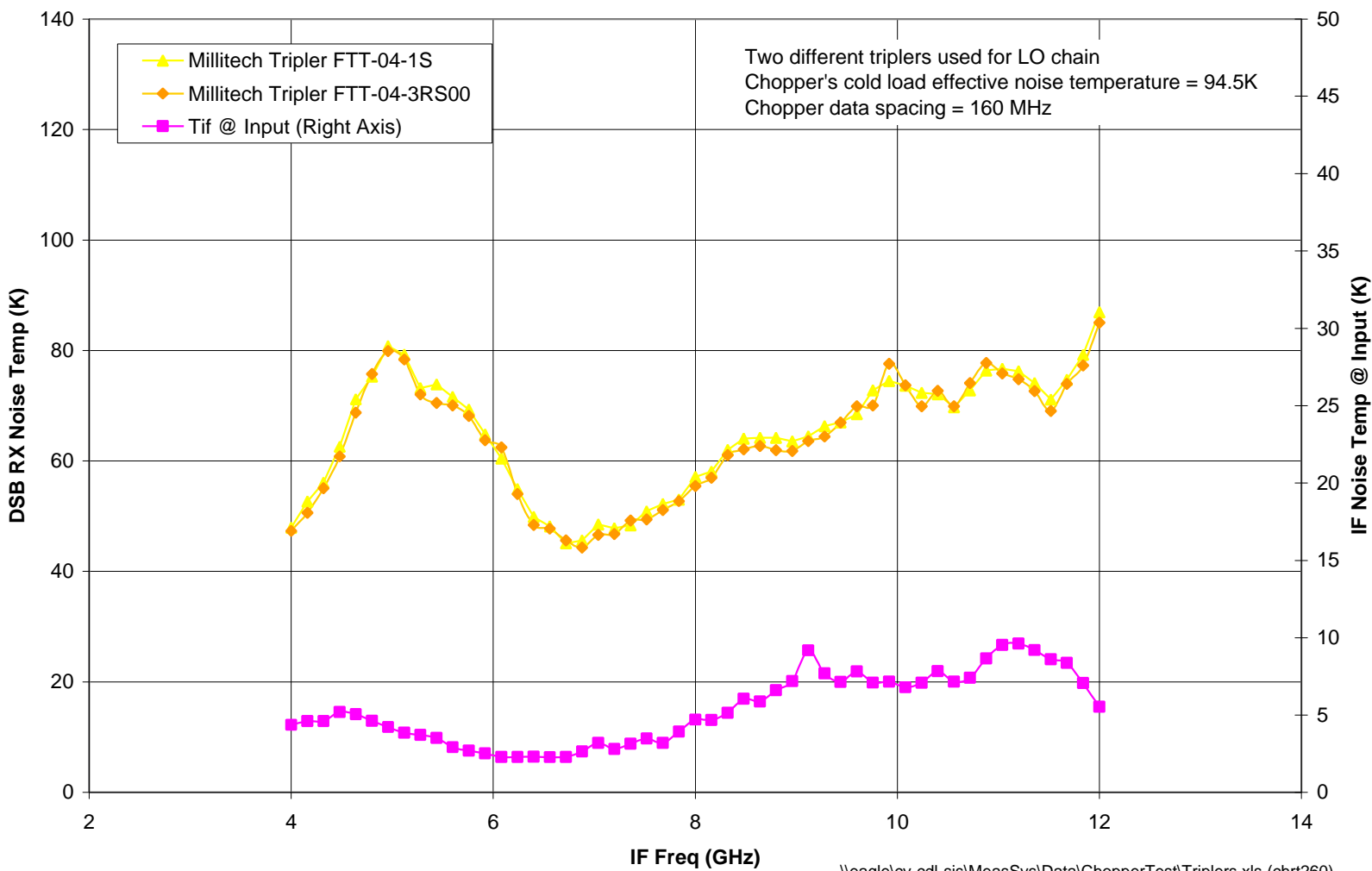

Figure 3: Receiver Noise Temperature at 210 GHz using Two Different Triplers

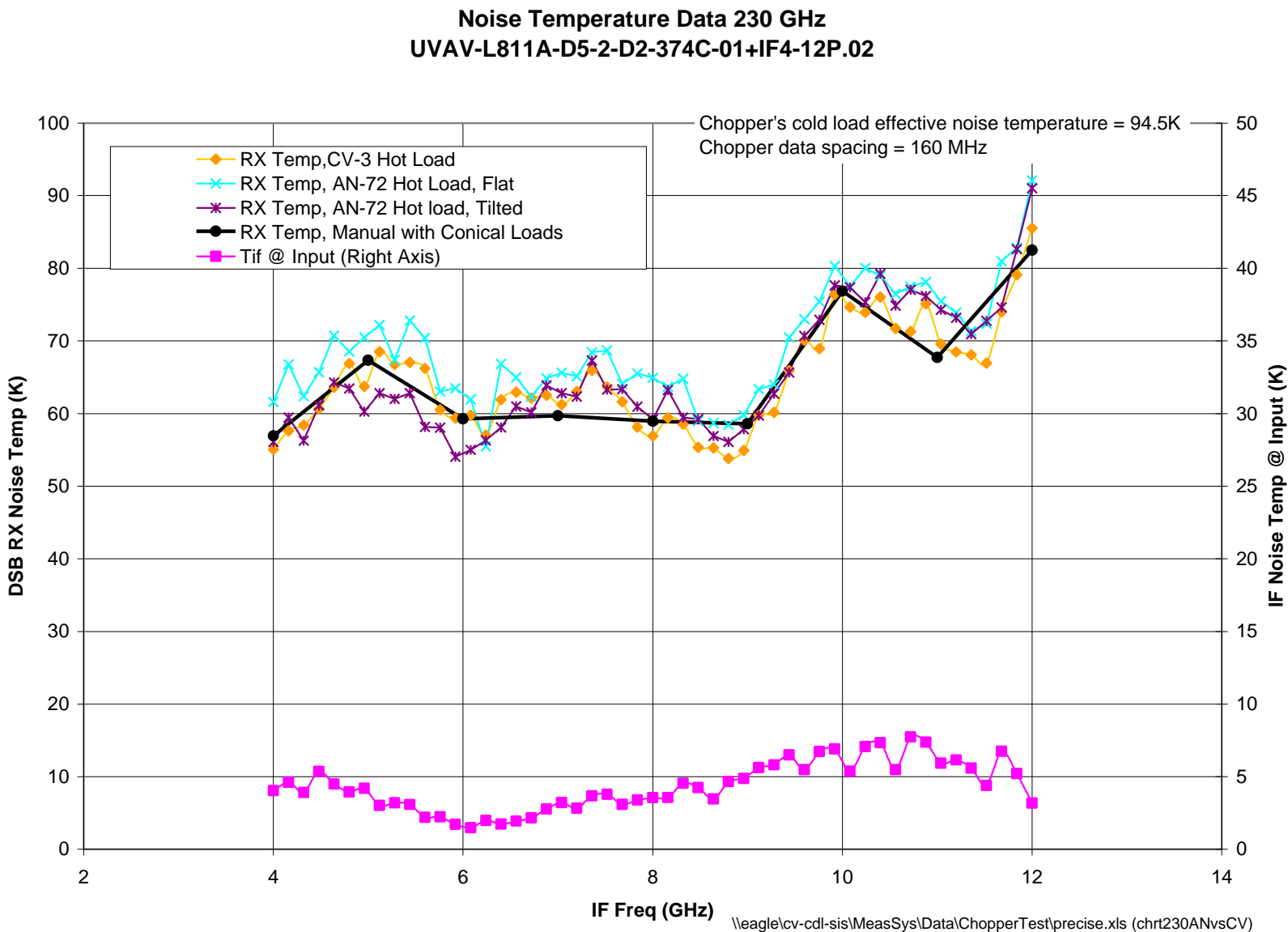

Figure 4: Comparison of Noise Temperatures Measured with Lab Standard and with Chopper Wheel using CV-3 and AN-72 for Hot Load

Noise Temperature Data 210 and 212 GHz
UVAV-L811A-D5-2-D2-374C-01+IF4-12P.02
2000-09-25

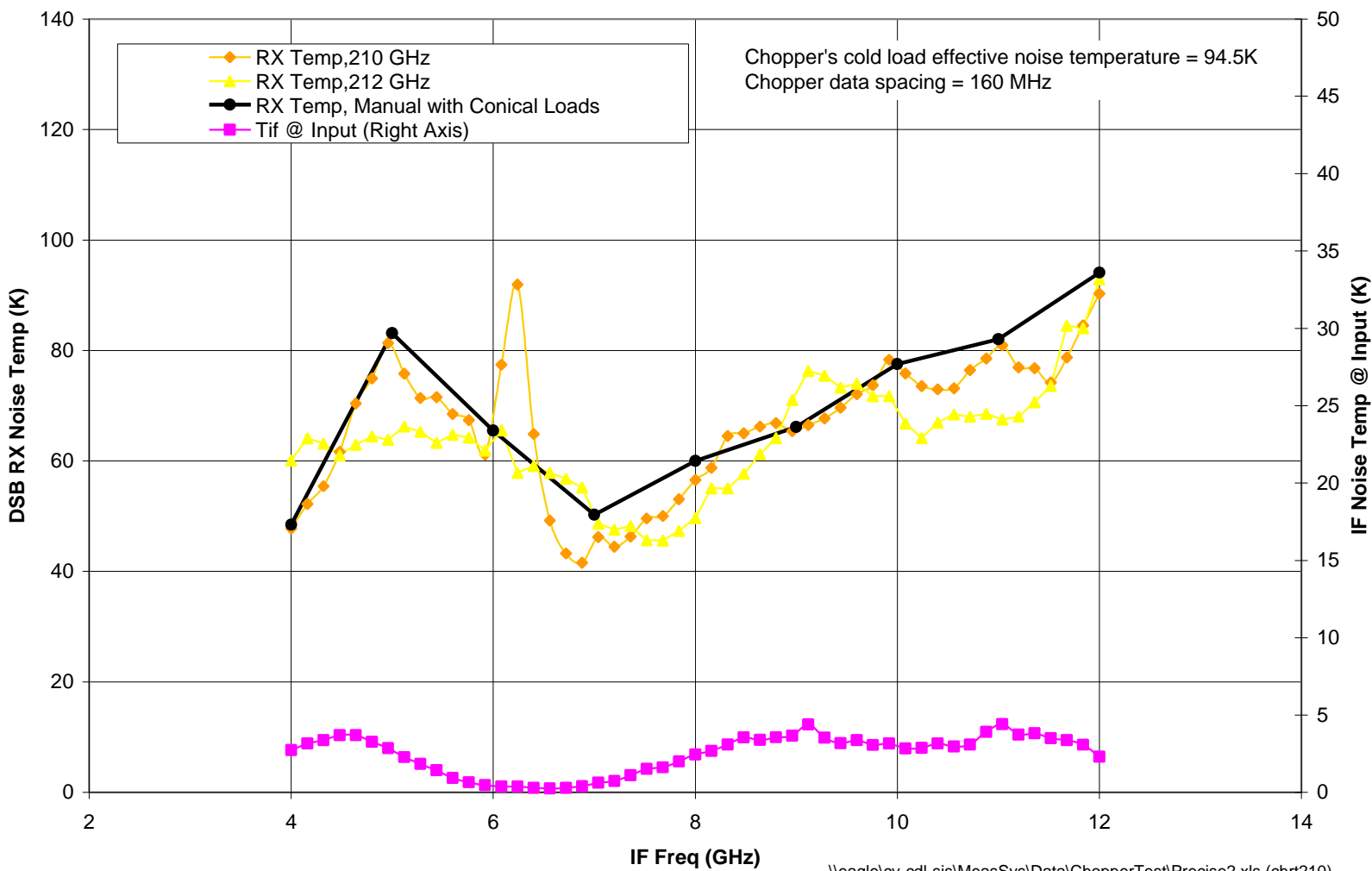

Figure 5: Receiver Noise Temperature At 210 and 212 GHz

Noise Temperature Data 230 GHz
UVAV-L811A-D5-2-D2-374C-01+IF4-12P.02

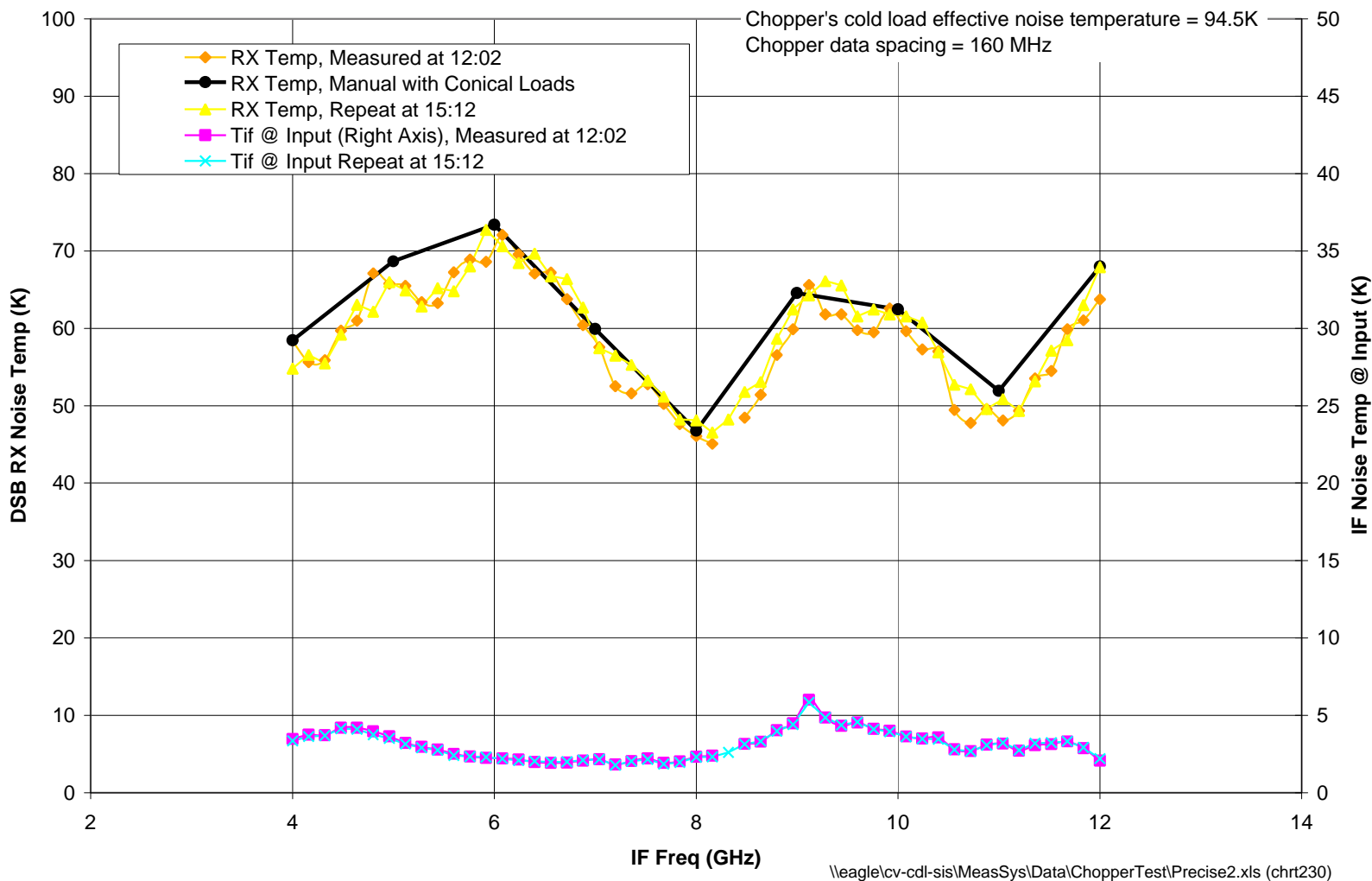

Figure 6: Receiver Noise Temperature at 230 GHz

Noise Temperature Data 250 GHz
UVAV-L811A-D5-2-D2-374C-01+IF4-12P.02
2000-09-25

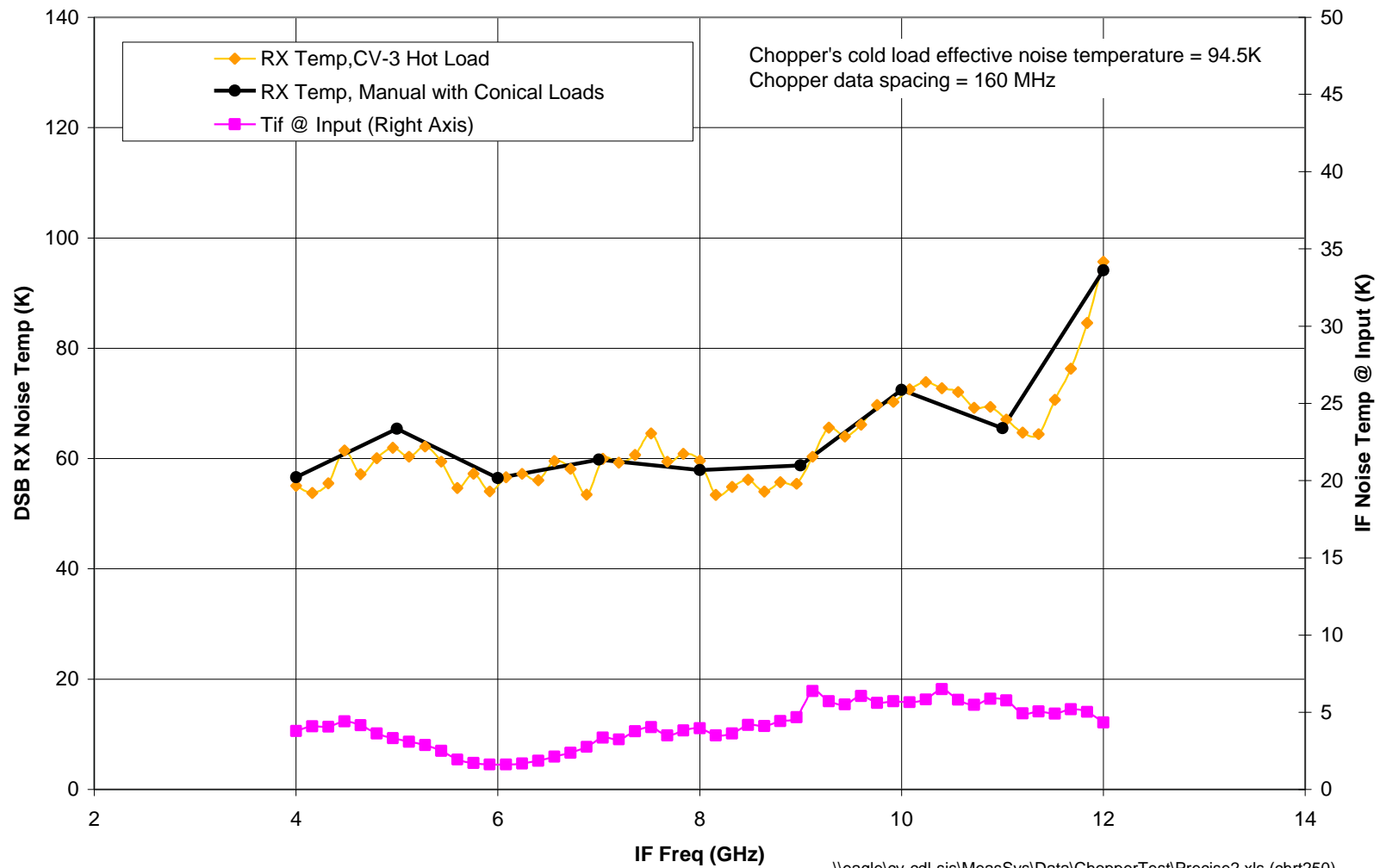

Figure 7: Receiver Noise Temperature at 250 GHz

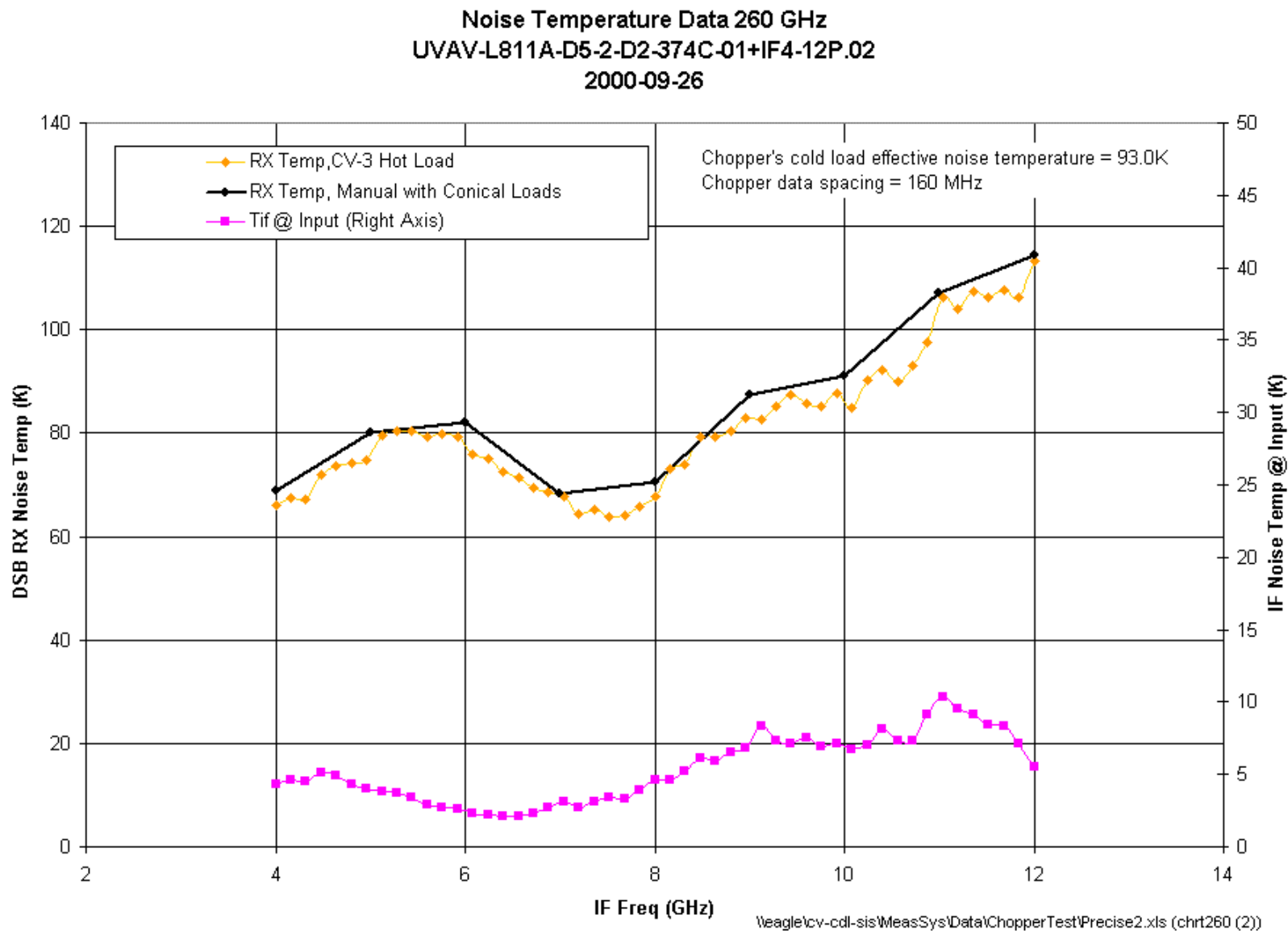

Figure 8: Receiver Noise Temperature at 260 GHz

Noise Temperature Data 270 GHz
UVAV-L811A-D5-2-D2-374C-01+IF4-12P.02
2000-09-26

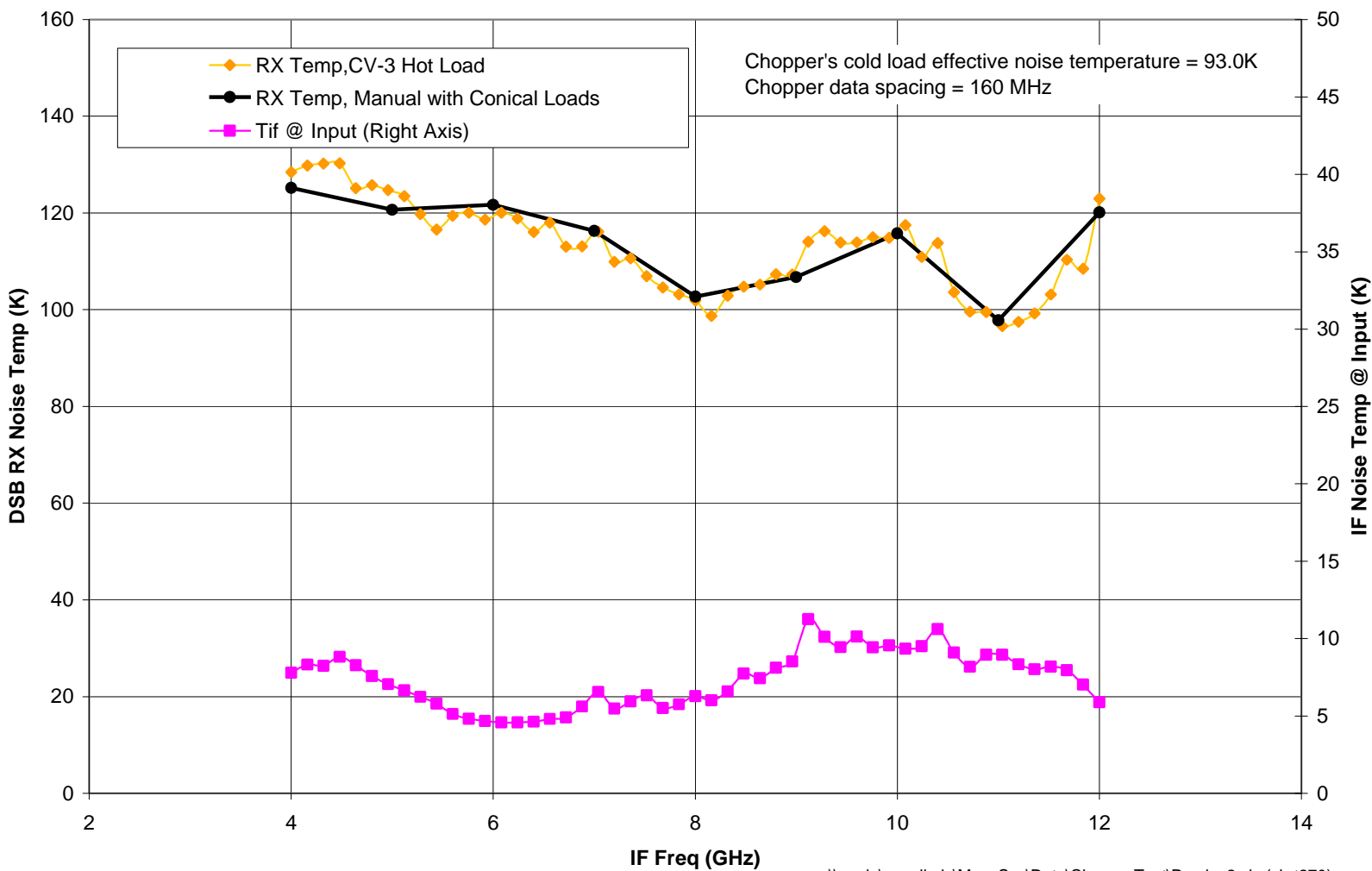

Figure 9: Receiver Noise Temperature at 270 GHz

\\eagle\cv-cdl-sis\MeasSys\Data\ChopperTest\Precise2.xls (chrt270)

Noise Temperature Data 280 GHz
UVAV-L811A-D5-2-D2-374C-01+IF4-12P.02
2000-09-26

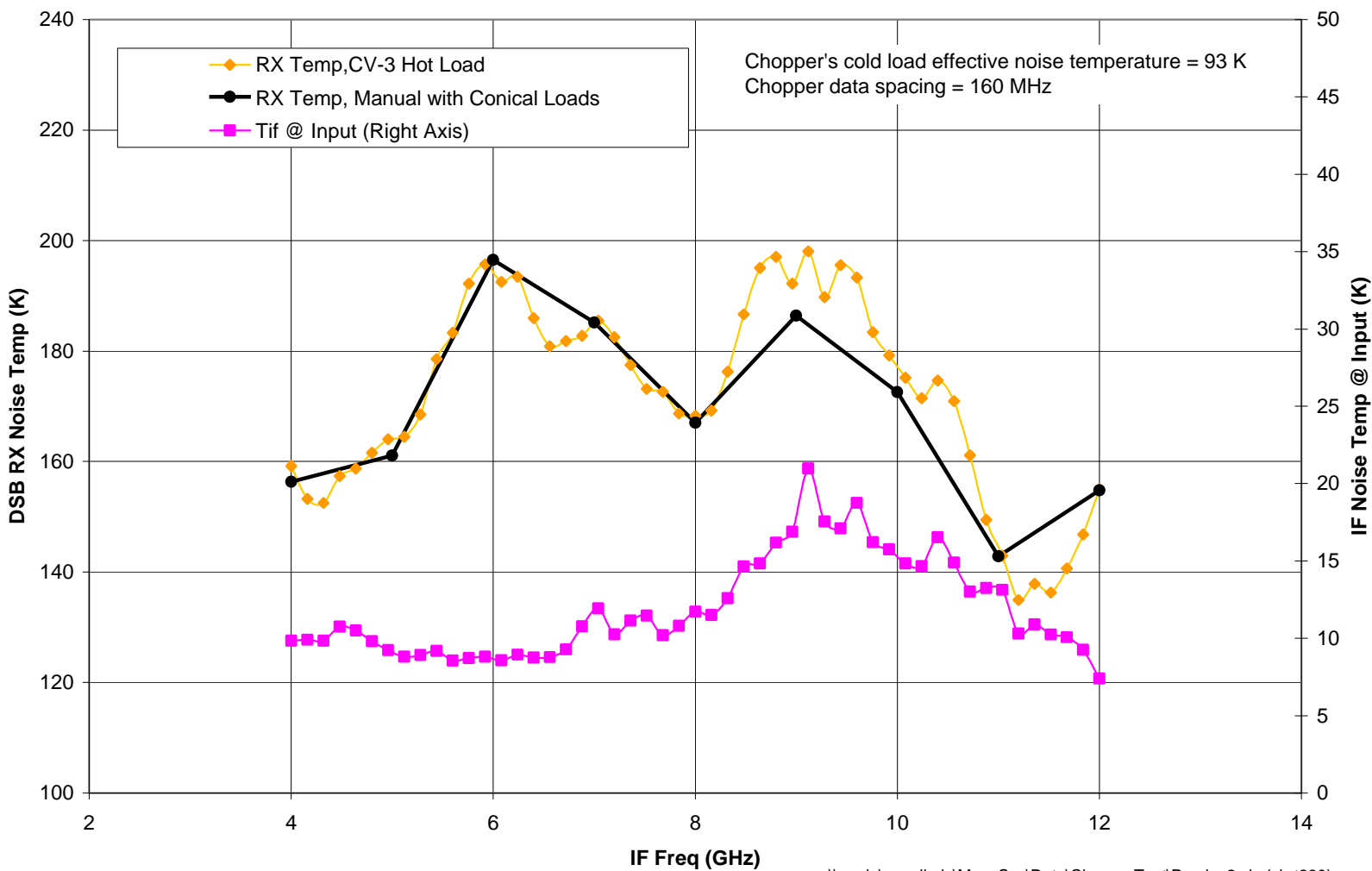

Figure 10: Receiver Noise Temperatures at 280 GHz

Discrepancy between Chopper and Conical Loads

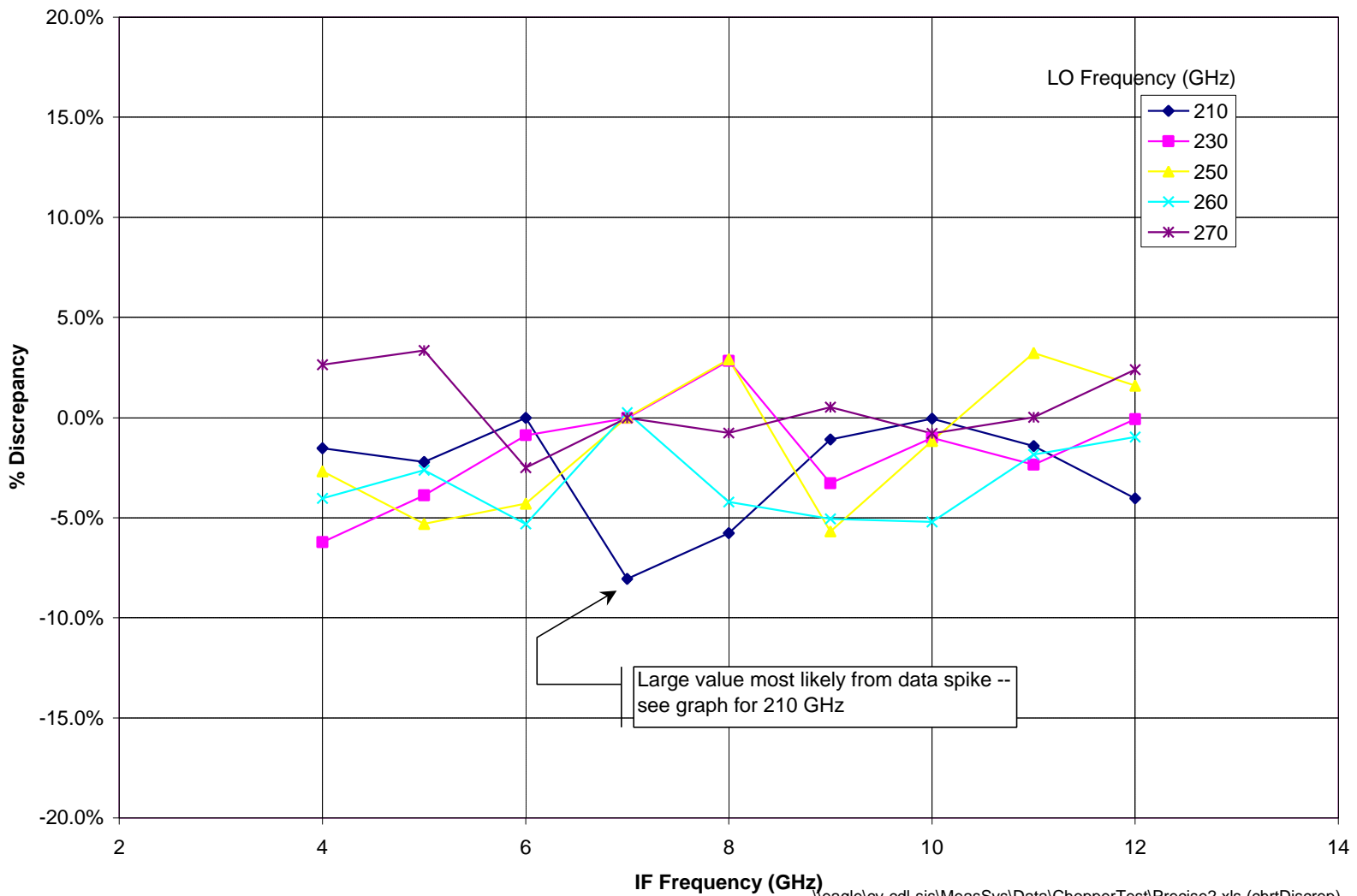

Figure 11: Discrepancy in Receiver Noise Temperature when Measured With Chopper and Conical Loads

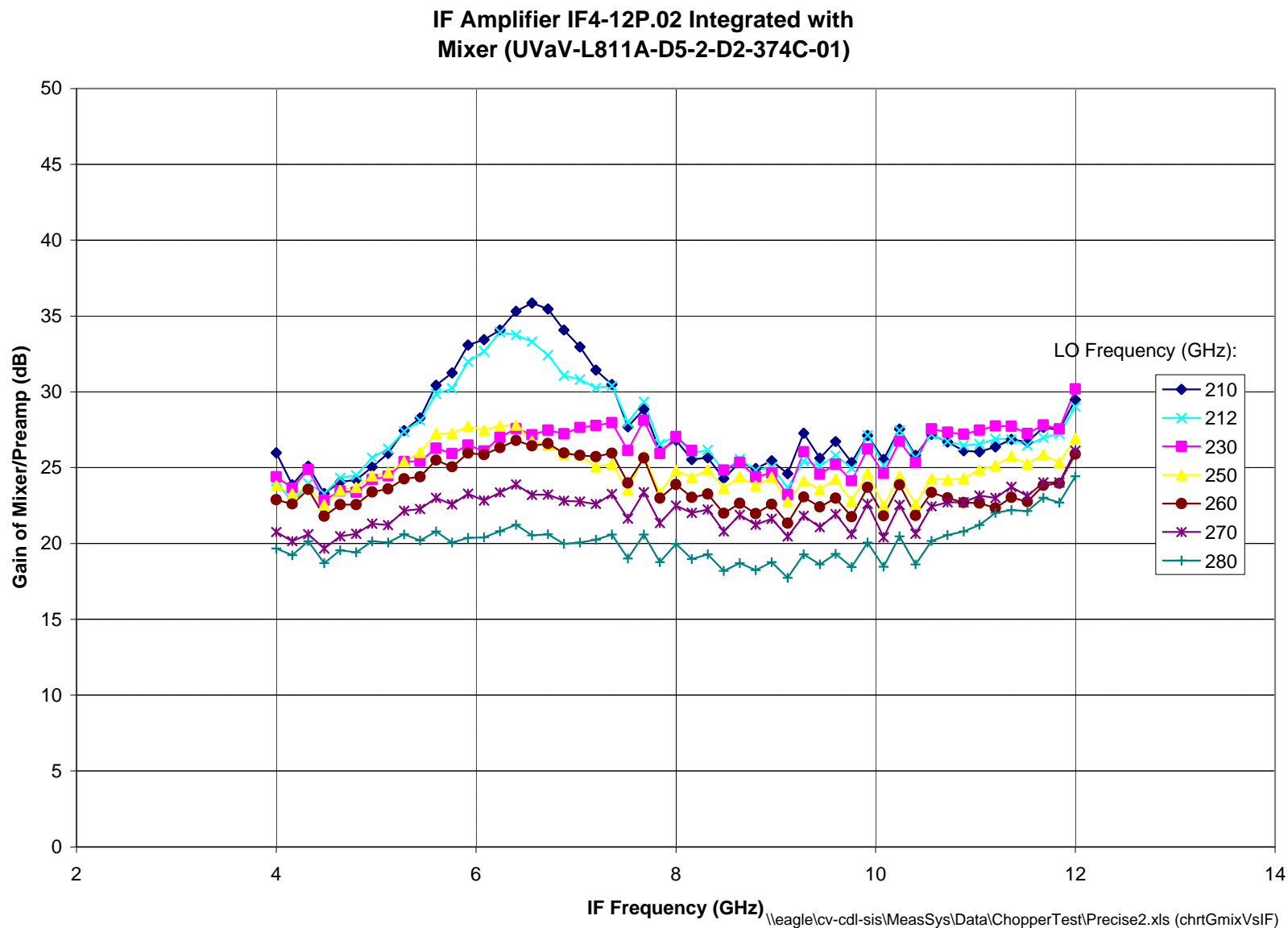

Figure 12: Gain of Mixer/Preamp vs. IF Frequency

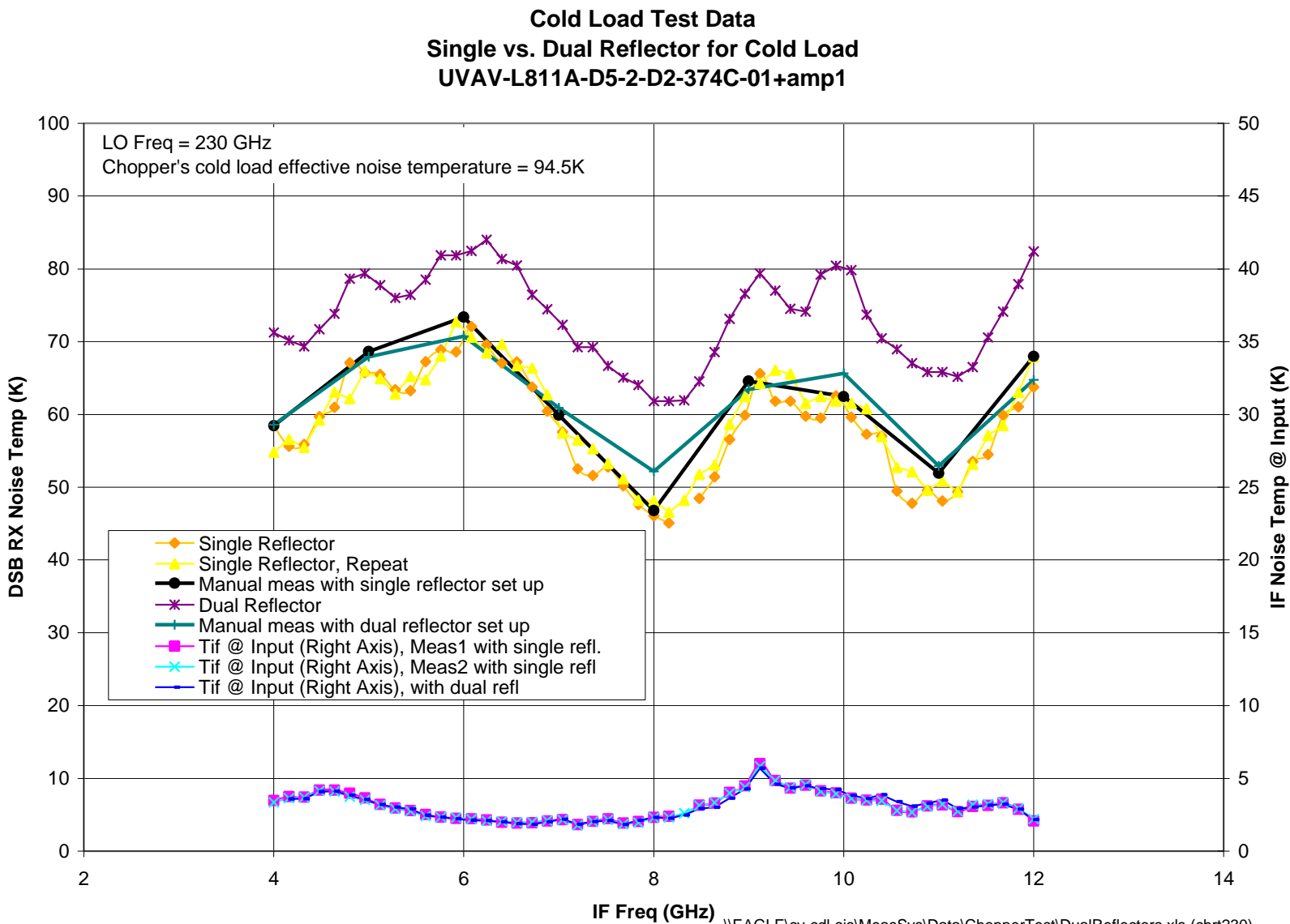

Figure 13: Measured Data for Dual Reflector Between Receiver and Cold Load

Cold Load Test Data
Single vs. Dual Reflector for Cold Load
UVAV-L811A-D5-2-D2-374C-01+IF4-12P.02

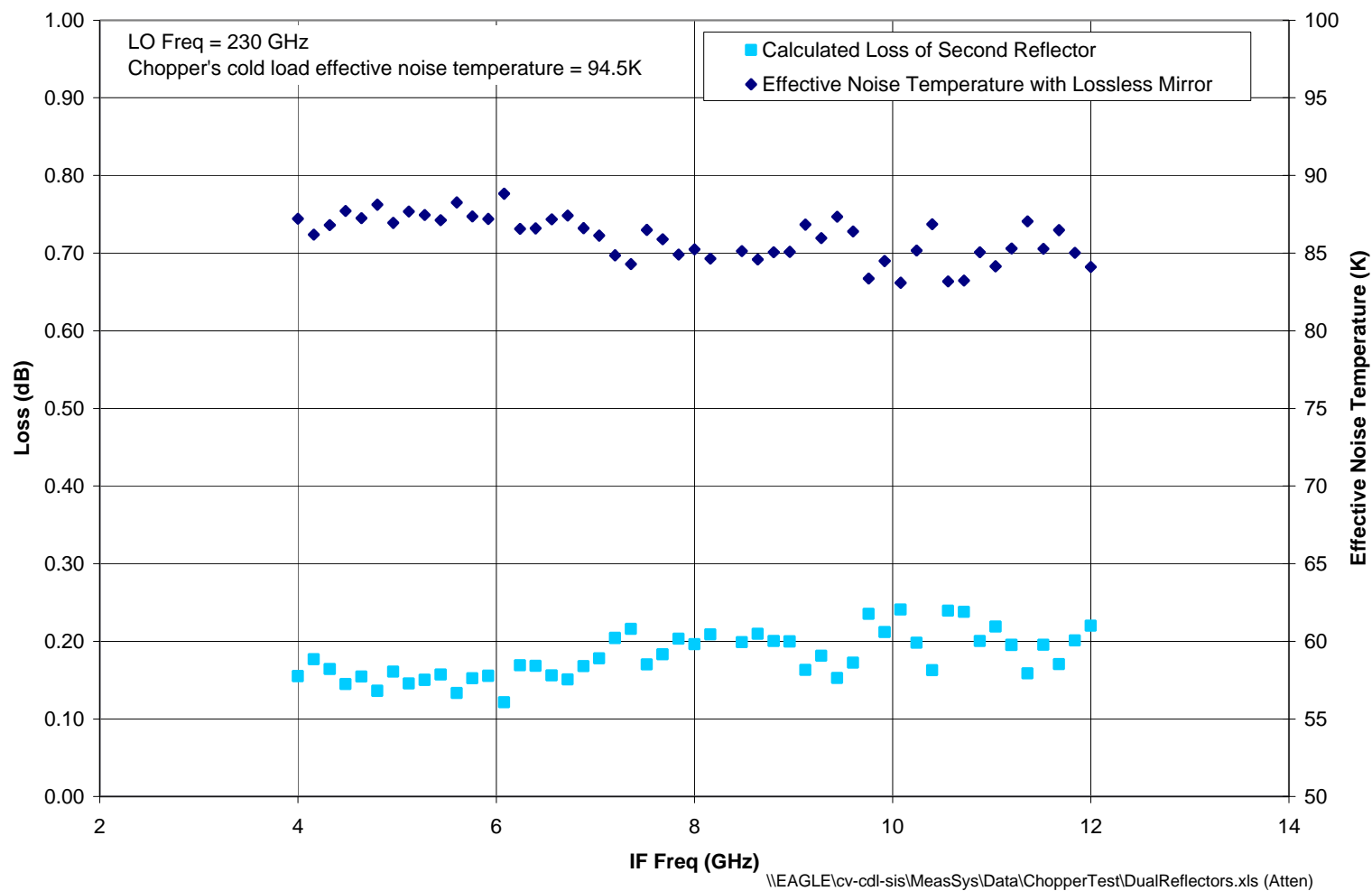

Figure 14: Calculated Loss of Second Reflector Between Receiver and Cold Load and Predicted Noise Temperature of Cold Load with No Reflectors