



# Memorandum

---

**To:** File

**From:** John Effland  
Gene Lauria

**Date:** 2003-09-26

**Revisions:** 2003-09-26 jee Initial

**Subject:** Band 6 Gain Stability Measurements of 26 September 2003

---

## Summary

Gain stability of the 2SB mixer-preamp was remeasured with all InP amplifiers removed from the measurement system, except for the mixer's preamplifiers. The IF system gain stability is now better than previous results<sup>1</sup> and is about  $2 \times 10^{-4}$  for 1-second integration time. This measurement more closely matches the configuration that will be used in the Band 6 cartridge.

Gain stability was measured for several different preamplifier and mixer bias levels but shows no significant changes compared with the nominal bias. Additional work is planned to change other parameters, such as mixer magnetic field and pump power, while measuring gain stability.

## Setup

The equipment setup is shown in Figure 1 and uses the sideband separating mixer-preamp UVA10-03-0403-L1362A-2-HJ-C12-L56-2-3-373-002-P.16.20 that is electrically identical to the ALMA Band 6 production version. An HP 35670 Dynamic Signal Analyzer fourier-transforms the video signal in real time and the results are then dumped to spreadsheets for further analysis and graphing.

Figure 2 shows the frequency spectrum at the IF input to the detector. Gain stability was measured using a 4 GHz high-pass filter, which means the effective noise bandwidth is essentially limited only by the preamplifiers.

## Results

In an attempt to improve the gain stability, the bias of both the preamp and mixer were varied as described below.

### 1.1 IF System: Spectral Density

The PSD response of the IF system, exclusive of the mixer-preamp, is shown in Figure 3 and is now  $5 \times 10^{-5}$  for a 1 second integration time. Compare this to the previous measurements that showed  $2 \times 10^{-4}$  for 1 second integration time when the IF chain included an InP amplifier operating in the Dewar at 4.2K. The PSD of the IF system which includes all amplifiers following the mixer-preamp were acquired by connecting the Radial IF switch to the IF load in the Dewar as shown in Figure 1.

---

<sup>1</sup> "Notes on Gain Stability Measurements of 13 Jun 2003," NRAO CDL Memo, Effland and Lauria, 4 Sep 2003, available at <http://www.cv.nrao.edu/~jeffland/AllanVar1.pdf>.

The PSD data are reconstructed from a number of sweeps on the FFT analyzer using different maximum frequencies. This is required to obtain adequate resolution at the lower frequencies. The PSD data in Figure 3 is just above the theoretical 8 GHz bandwidth mark, which provides a check of the calibration. It's not surprising that the measured  $\Delta V/V$  is higher than the theoretical value because the shape of the noise passband from the mixer-preamp has a drop in the middle of the IF band as shown in Figure 2. That most likely yields an effective noise bandwidth that's smaller than 8 GHz and hence the measured  $\Delta V/V$  should be greater than the theoretical value.

## 1.2 Mixer-Preamp: PSD

Gain stability of the actual mixer-preamp (which also includes the contribution from the measurement setup) for the entire 8 GHz IF bandwidth is shown as power spectral density in Figure 4. For this case, which is at nominal mixer-preamp and mixer bias, gain stability is  $2.5 \times 10^{-4}$  for 1 second integration time. A check of the calibration is given by the diamond, which is the theoretical  $\Delta V/V$  assuming an 8 GHz bandwidth.

Gain stability of the mixer-preamp with the *preamp* biased at two other points is shown in Figure 5 and Figure 6. For both cases, the  $\Delta V/V$  is perhaps slightly worse compared to nominal mixer-preamp bias. As a final test, the *mixer* was then biased at two other points, as shown in Figure 7 and Figure 8 and again  $\Delta V/V$  at 1 second may be just slightly worse than at nominal bias.

## Acknowledgements

The authors would like to thank A.R. Kerr, and G. Ediss for their useful comments. We wish to especially thank R. Groves for assisting us in acquiring the data.

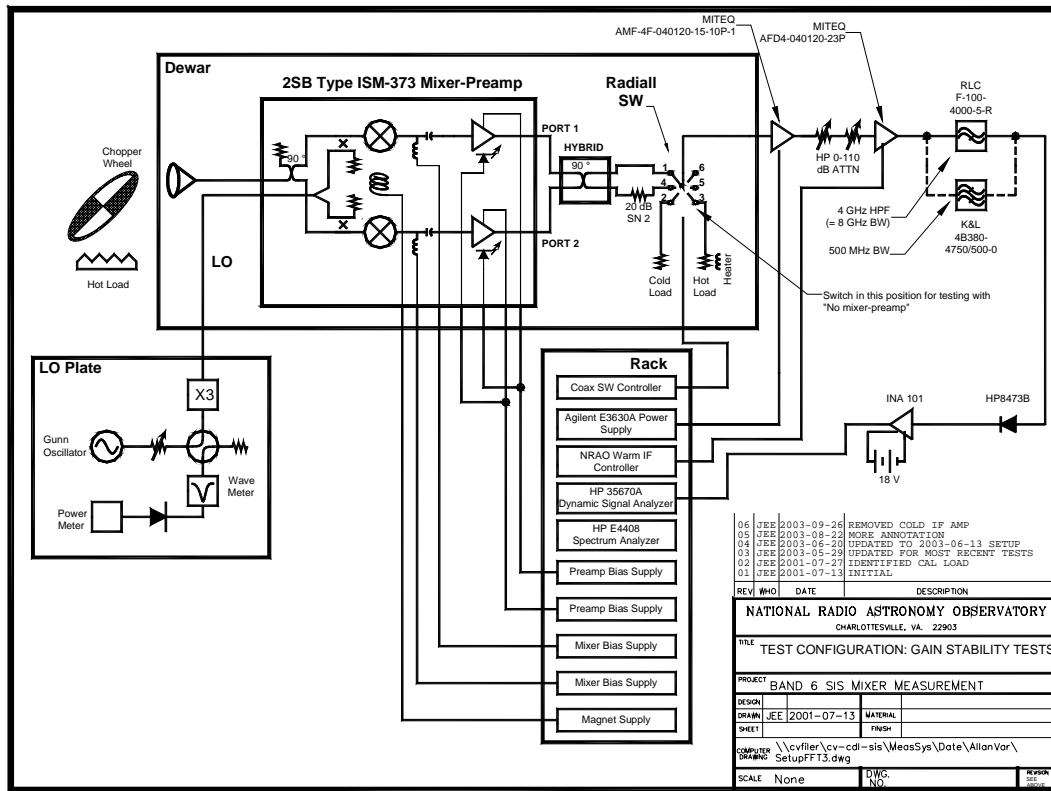

Figure 1: Equipment Setup with only warm GaAs IF amplifiers.

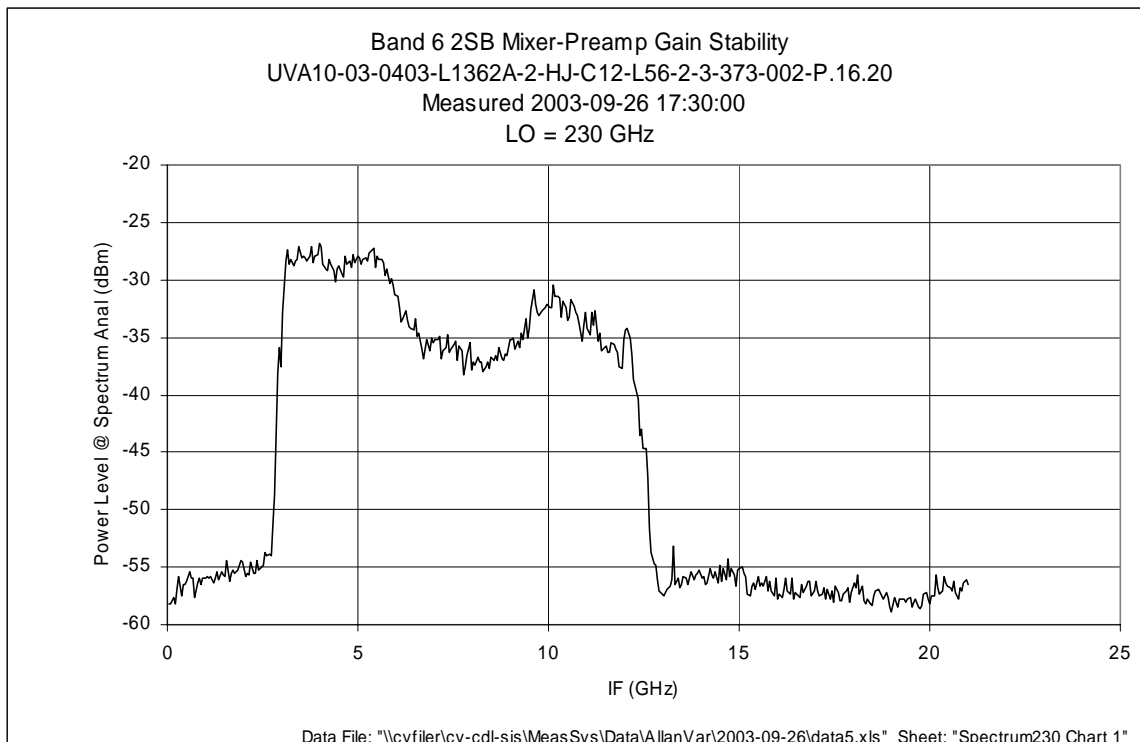

Figure 2: Spectrum at input to detector using nominal bias

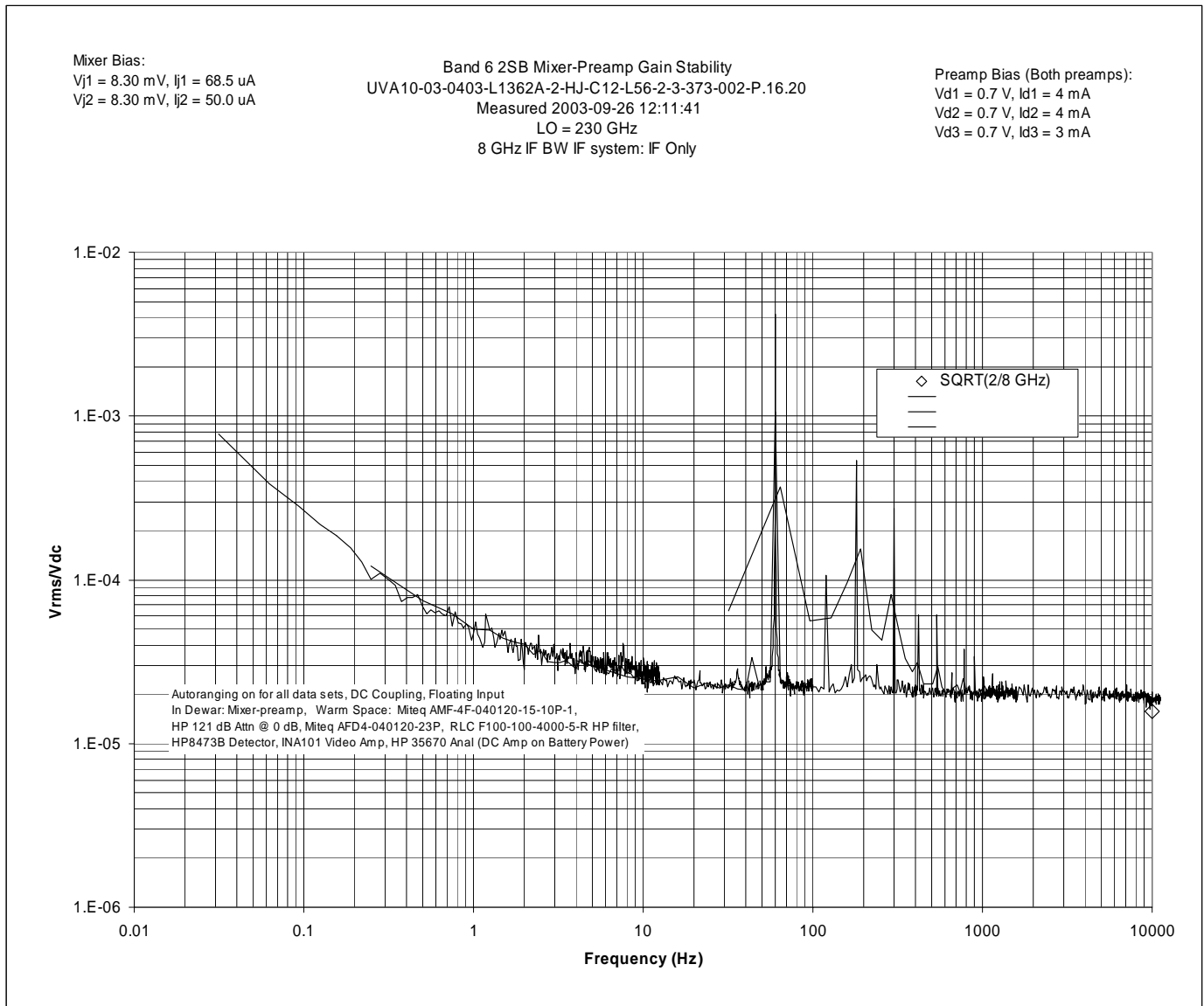
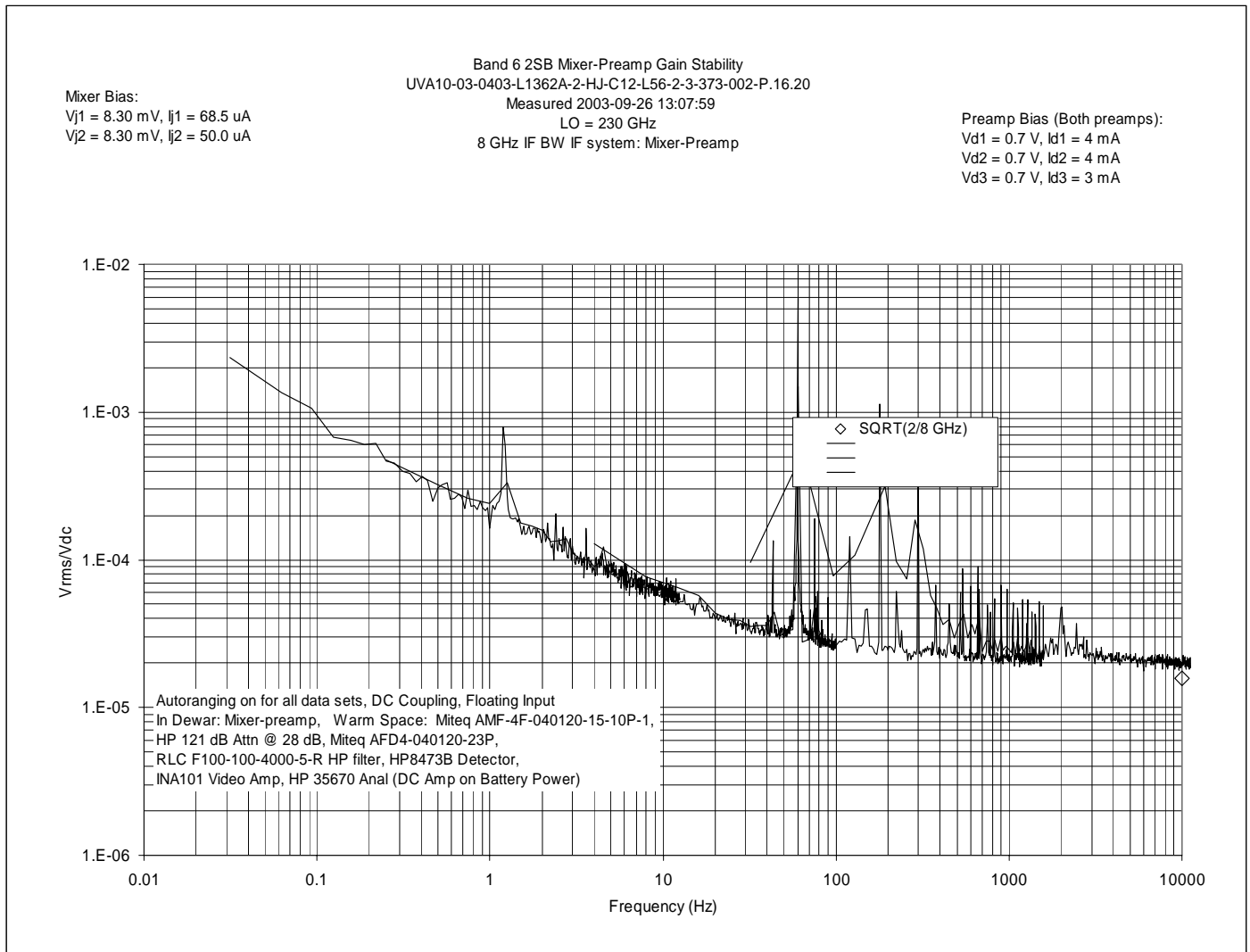

Figure 3: Spectral Density for IF System

Data File: "\\cvfiler\cv-cdl-sis\MeasSys\Data\AllanVar\2003-09-26\data5.xls" Sheet: "GainStab(4) Chart 1"



**Figure 4: Spectral density for mixer-preamp - Nominal Bias**

Data File: "\\cvfiler\cv-cdl-sis\MeasSys\Data\AllanVar\2003-09-26\data5.xls" Sheet: "GainStab(6) Chart 1"

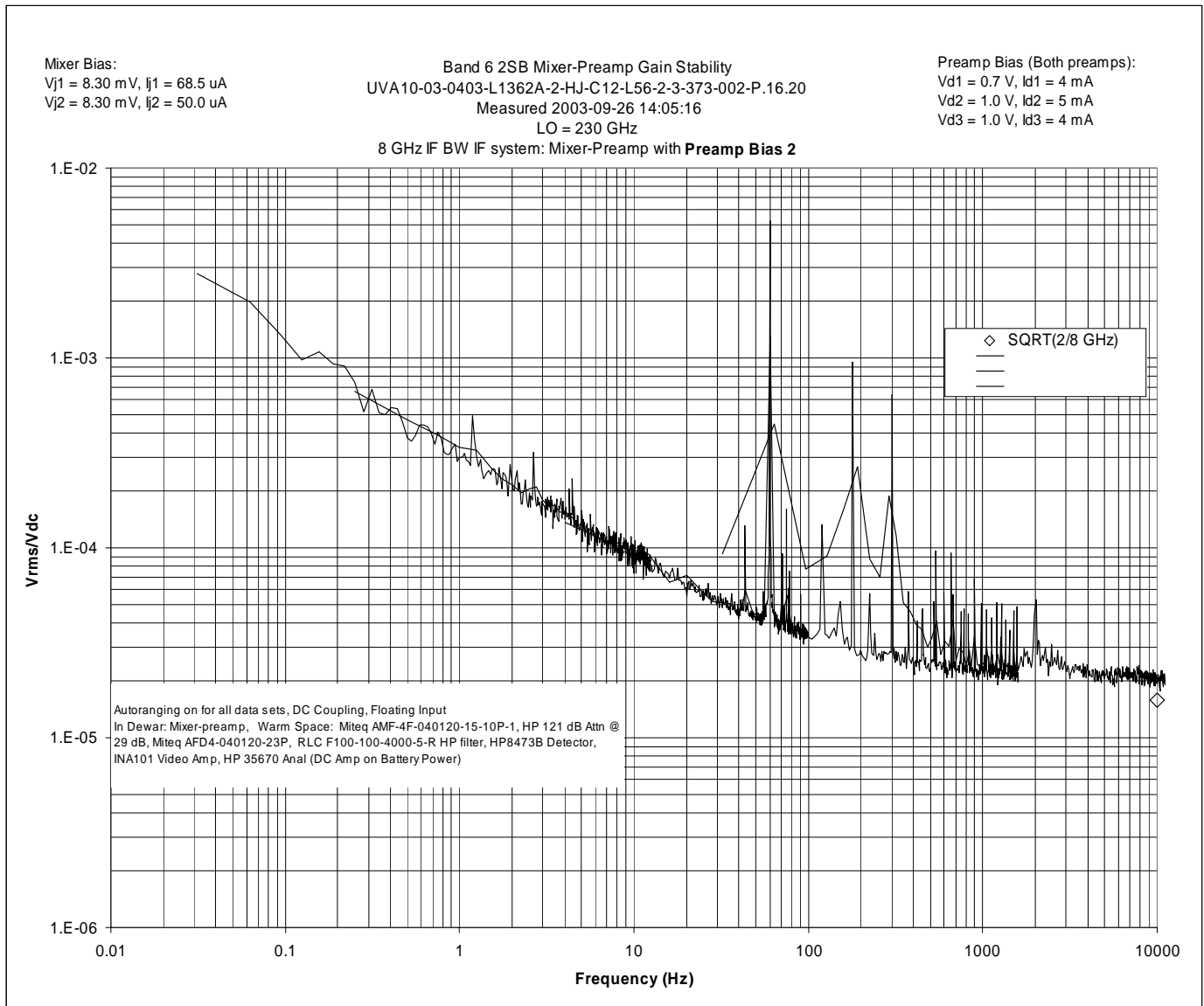

Figure 5: Spectral density for mixer-preamp with preamp at bias state 2

Data File: "\\cvfiler\cv-cdl-sis\MeasSys\Data\AllanVar\2003-09-26\data5.xls" Sheet: "GainStab(7) Chart 1"

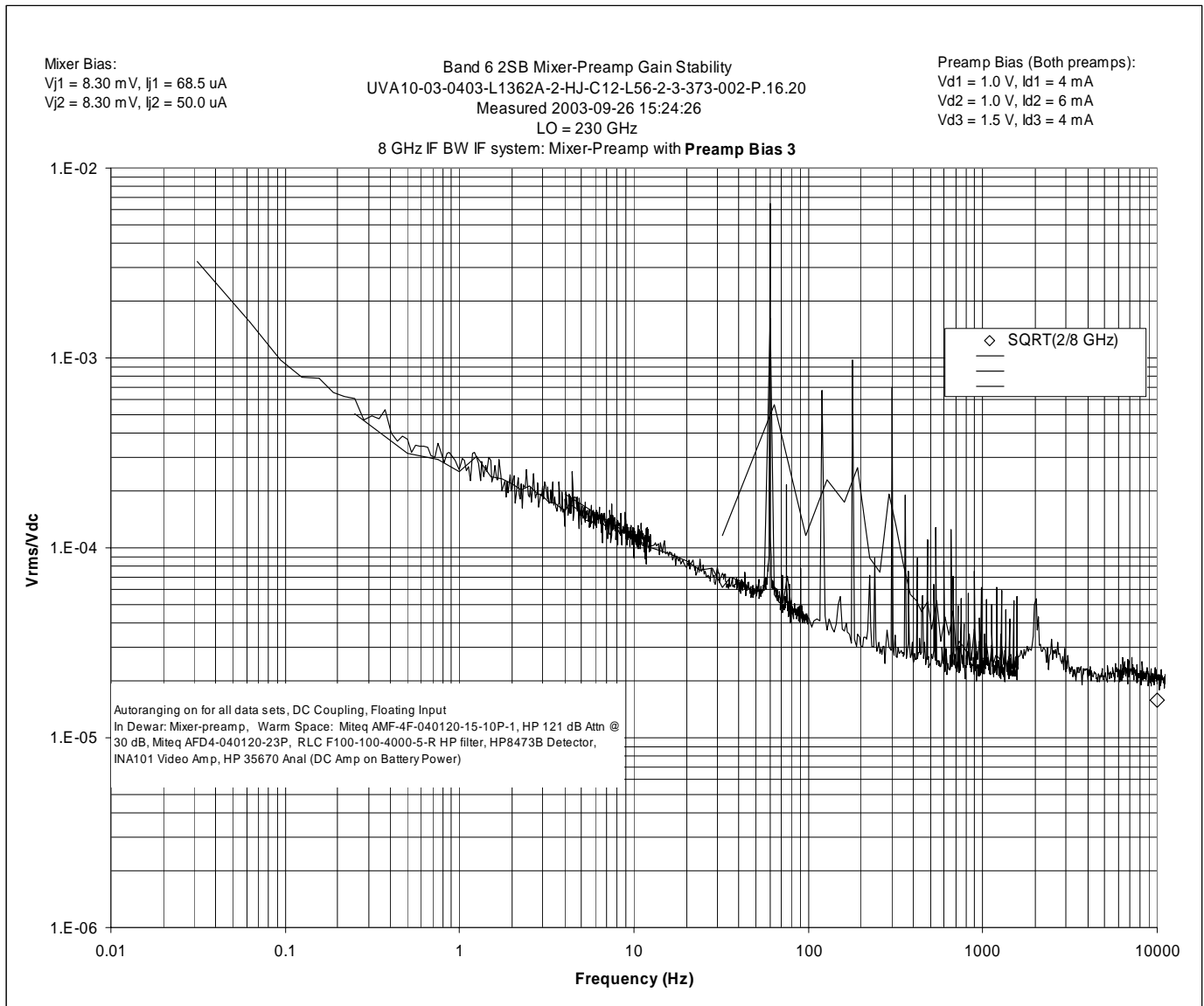

Figure 6: Spectral density for mixer-preamp with preamp at bias state 3

Data File: "\\cvfiler\cv-cdl-sis\MeasSys\Data\AllanVar\2003-09-26\data5.xls" Sheet: "GainStab(8) Chart 1"

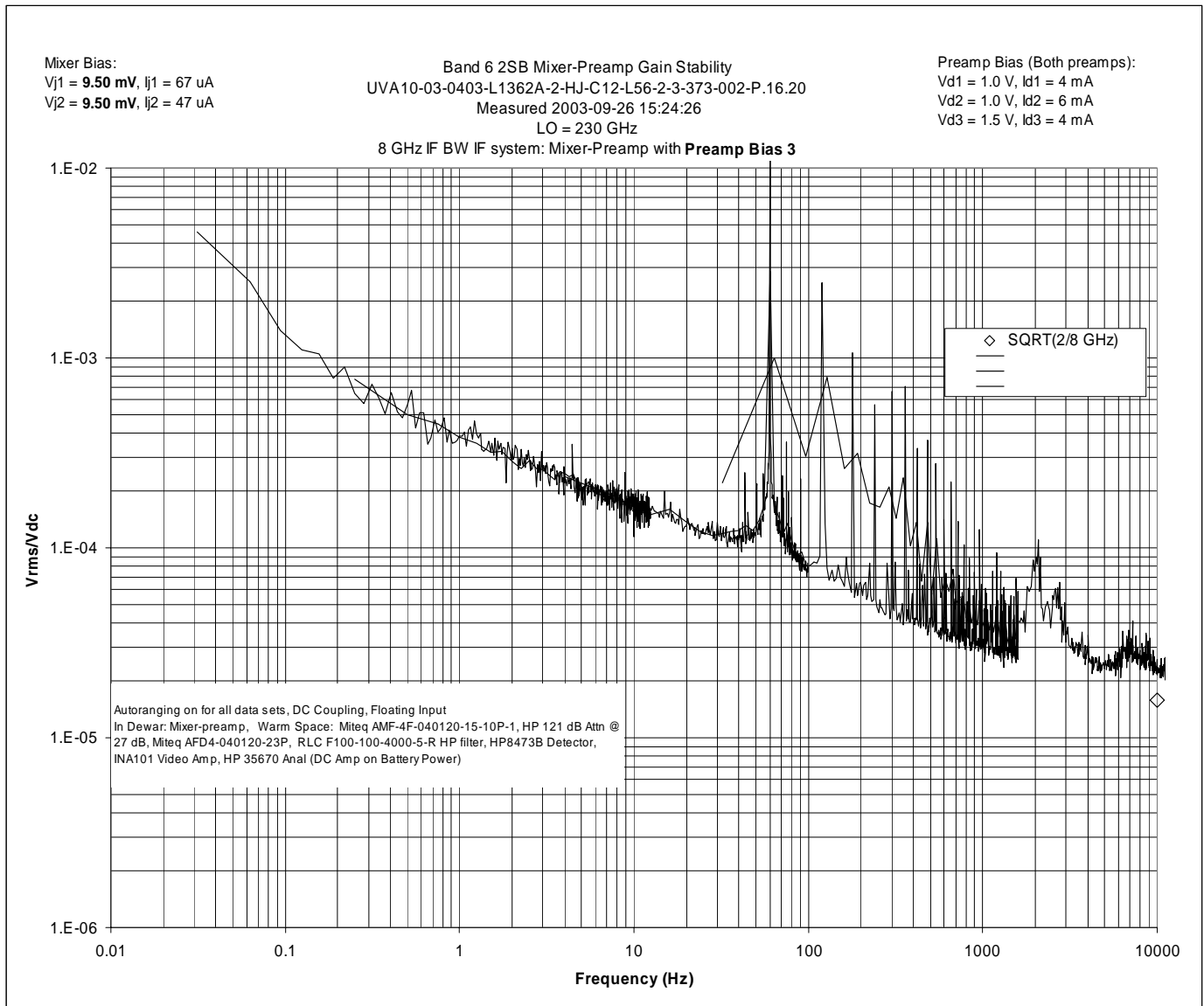

Figure 7: Spectral density for mixer-preamp with preamp at bias state 3 and mixer at bias state 2

Data File: "\\cvfiler\cv-cdl-sis\MeasSys\Data\AllanVar\2003-09-26\data5.xls" Sheet: "GainStab(9) Chart 1"



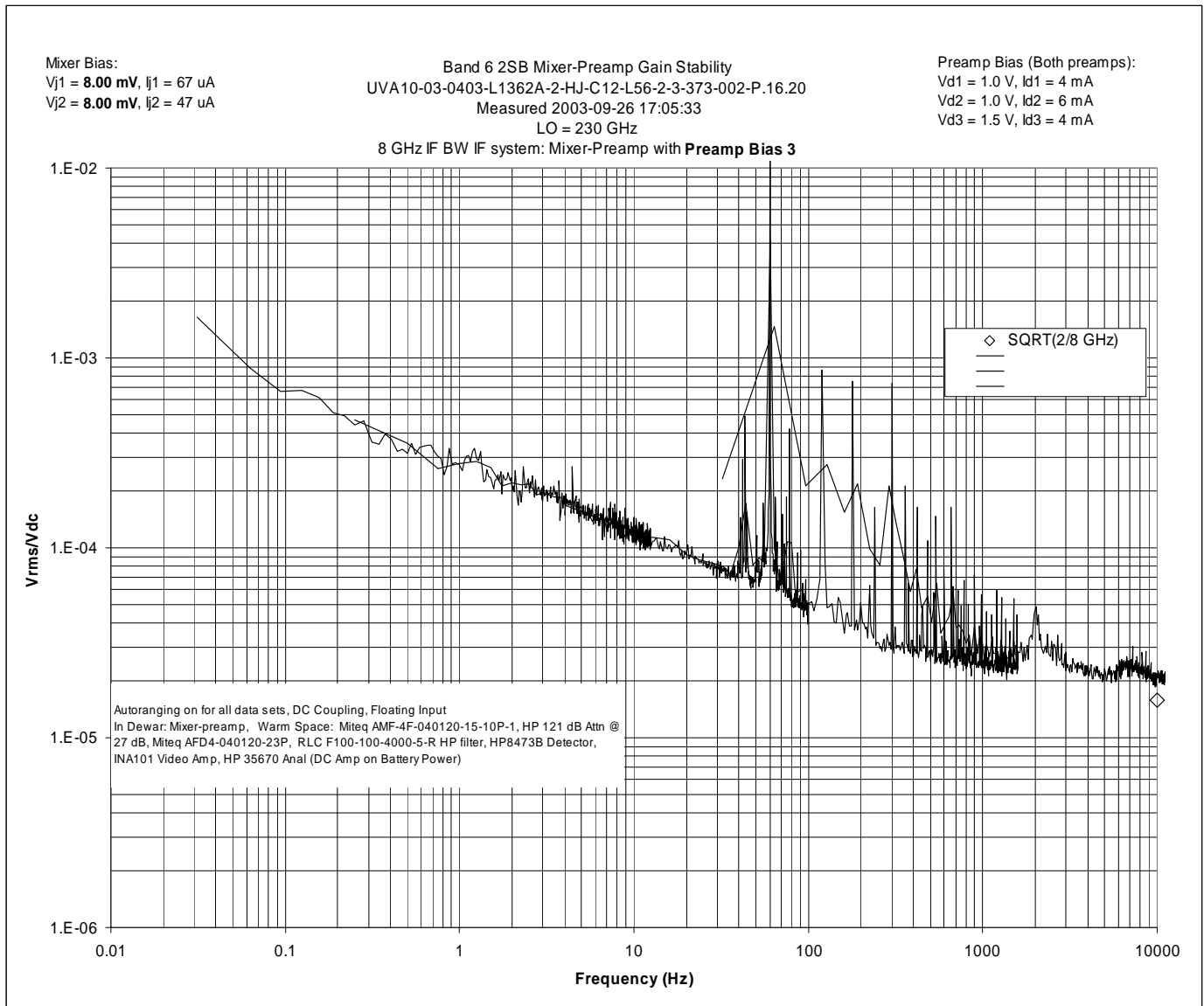

Figure 8: Spectral density for mixer-preamp with preamp at bias state 3 and mixer at bias state 3

Data File: "\\cvfiler\cv-cdl-sis\MeasSys\Data\AllanVar\2003-09-26\data5.xls" Sheet: "GainStab(9) Chart 1"