



Memorandum

To: R. Bradley S. Thacker

cc: K. Crady G. Ediss
R. Groves A. R. Kerr
S. -K. Pan J. Webber

From: J. Effland

Date: 27 Feb 2001

Subject: LO Requirements for Automated Mixer Testing

Introduction

This memo begins a dialog concerning the LO's needed for SIS mixer testing. Automated LO's are essential in our test system for reducing the time needed to test mixers, because the present arrangement requires manual LO frequency changes and is now the most time consuming task involved in mixer testing.

Included here are preliminary technical requirements, interface definitions, and schedule requirements for the LO's. The highest priority LO will support mixer development of ALMA Band 6, and as detailed below, the frequency range far exceeds present LO specifications for that band. Two separate LO systems might be needed to support the 200 GHz - 290 GHz frequency range.

Two test systems are under construction at the CDL for ALMA SIS mixer development testing. Four additional test systems are planned for ALMA SIS mixer production testing, but funding and schedules for the production system are uncertain, so the focus of this memo is on the development systems.

Frequency Requirements

Two different scenarios are required for ALMA mixer testing:

- 1) tests during continued development, and
- 2) production testing.

LO's used for development testing must span a larger frequency band than the specified ALMA bands. Ongoing development testing in Band 6 requires the present, manually tuned LO's to span about 5% above and 5% below the ALMA band edges. The frequency bands specified in this memo for development testing all assume the same 5% extension at the band edges.



Phase stability and frequency accuracy of the LO must be sufficient to allow automated measurements of mixer image rejection. While it is difficult to be more quantitative at this time, the general consensus is that the LO requires phase locking to provide the requisite frequency accuracy.

Table 1 lists the frequency band requirements, ordered from highest to lowest priority.

ALMA Band Number	ALMA Specified Frequency Range (GHz)	LO Frequency Range Required for SIS Mixer Development Testing (GHz)	Estimated Power Requirements
6	211 - 275	200-290	30 mW before the final tripler
9	602 - 720	572-756	TBD
3	89 - 116	85 - 122	TBD

Interfaces

A top-level schematic obtained with input from D. Thacker for the ALMA Band 6 LO is shown in Figure 1. The black rectangle represents a first attempt at identifying interfaces between the LO group's hardware, which lies inside the rectangle, and hardware provided by the SIS group. LO interfaces for the other bands will be specified later.

The triplers shown in Figure 1 are presently used in the manually tuned SIS measurement system, and the required input frequency range is specified for each on the drawing.

Table 2 provides additional interface details.

Description	Type	Description
AC Line	INPUT	The LO will include the necessary power supplies.
Frequency Reference	INPUT	Spans 8 GHz to 11 GHz to allow the selection of the desired LO frequency. The source for this can be either a commercial signal generator (e.g., 83711 @ \$24K new) or the ALMA reference generator under development in Socorro.
10 MHz reference	INPUT	To phase lock the 50 MHz oscillator and the 8-11 GHz frequency generator.
AMB Computer Interface	INPUT	Designed using the standard ALMA CAN bus interface specification, this includes signal to direct the LO control board to autonomously set LO mixer bias and YIG oscillator frequencies.
Frequency Output (input to triplers supplied by SIS group)	OUTPUT	WR-10 waveguide, 30 mW power, Frequency ranges: 66.7 GHz to 86.7 GHz 86.6 GHz to 96.7 GHz



The SIS group will use a Hughes waveguide modulator and appropriate driver to control the output level. Existing millimeter wave triplers owned by the SIS group will be initially used at the output to save time and money.

Schedule

An automated LO for Band 6 would be immediately useful, but given budgetary constraints, that's impractical. A realistic schedule for Band 6 LO development is important. Once development of this LO commences, it would be useful for the responsible engineer to start attending our weekly 30-minute long status meetings so that we can effectively track the development schedule.

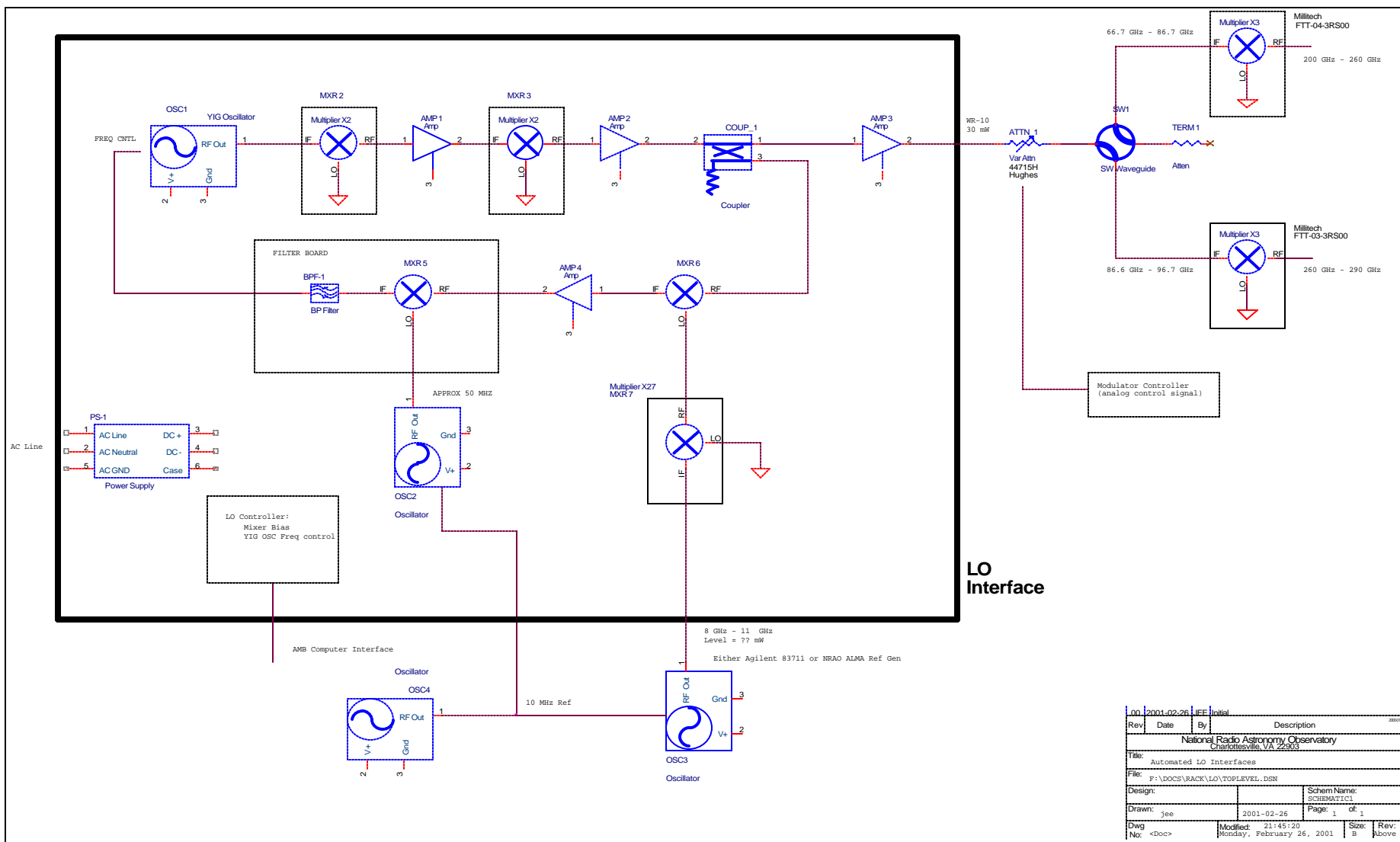

Figure 1: Interface Definitions for ALMA Band 6 LO