

SRD-99

- data recorder
- up to 8 inputs 0/4 - 20 mA or Pt100, Pt500, Pt1000
- 1 digital input for recording release
- RS-485 / Modbus RTU
- graphic display



The **SRD-99** device is designed to record and display current values as well as to present technological parameters in the form of graphs. The device is equipped with 8 temperature (Pt100, Pt500, Pt1000) or current (in the 0/4-20 mA standard) inputs and one impulsive (digital) input for controlling the recording process. The device has the memory capacity of 2 MB which gives max. 500 000 data recordings altogether. The internal analogue-digital converter has a 12 bit resolution, which provides high recording resolution results. Additionally, individual alphanumeric description (text) of each of the recorded channels is possible. The menu assisted with full text descriptions makes the unit configuration process quite easy. However, due to a significant number of configured parameters it is advised to use the attached configuration software for PCs.

- a legible graphic display 128 x 64 points, with a backlight,
- current graph of trends for each channel respectively,
- free configuration and recording software,
- insulated communication interface RS-485.

Exemplary pin assignment

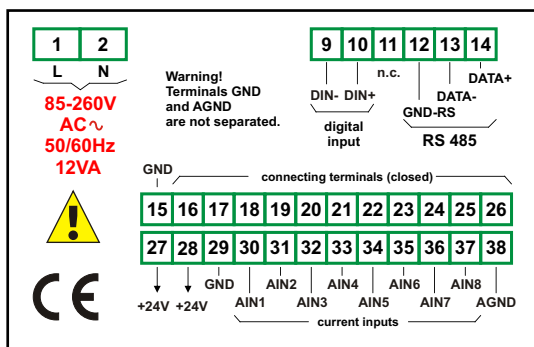

Ordering

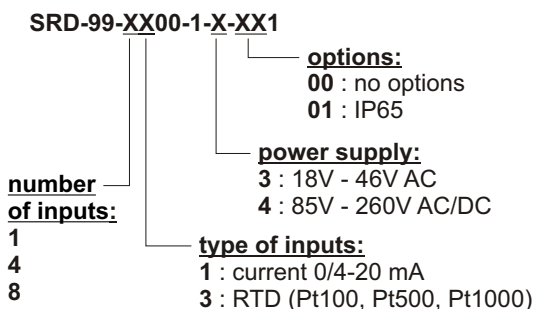

An example of what the display looks like

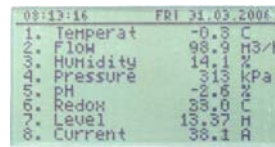

8-channel view displayed at the same time

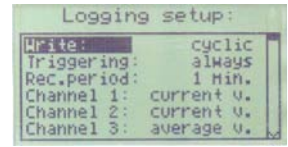

Recording parameters

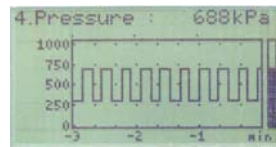

The history of the process in time

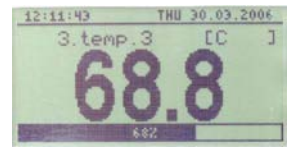

The current value of the measurement signal
Height of the digits: 18 mm

Configuration software

- **SRD Toolkit** used for data recorder configuration (Windows environment),
- **Loggy Soft** for transferring, reporting, archiving and displaying the recorded data (Windows environment).

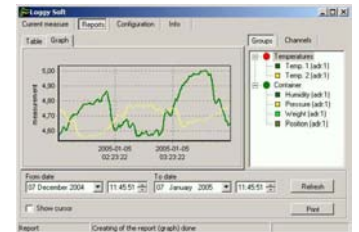

Technical data

- Power supply voltage:** 19V + 50V DC; 16V + 35V AC or 85 + 260V AC/DC
- Power consumption:** typical 7 VA; max. 12 VA
- Display:** lit, graphic LCD, 128 x 64 points, with backlight
- Measuring inputs:** 1, 4 or 8; Pt100; Pt500; Pt1000 (2 and 3-conductor connection) or 0/4-20 mA inputs; common earthing
- Digital input:** 1 input 24V DC
- Sensors supply:** 24 V DC±5% / 200 mA, not separated from measuring inputs
- Communication interface:** RS-485, galvanically separated
- Transmission protocol:** MODBUS RTU
- Transmission speed:** 1200 - 115200 bit/sec.
- Memory capacity:** 2 MB (500 000 data recordings)
- Type of protection:** IP 65 (front side when an additional frame is installed); IP 40 (front side); IP 20 (case and connection clips)
- Working temperature:** 0°C do + 60°C
- Storage temperature:** -15°C do + 80°C
- Humidity:** up to 90% without condensation
- Case:** board
- Case material:** NORYL - GFN2S E1
- Case dimensions:** 96 x 96 x 100 mm
- Panel cut-out dimensions:** 90,5 x 90,5 mm
- Installation depth:** min. 102 mm
- Board thickness:** max. 5 mm